

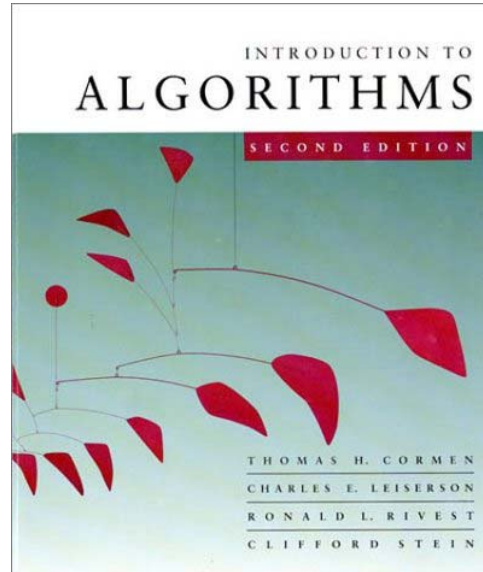

CS 5633 -- Spring 2008



Single Source Shortest Paths

Carola Wenk

Slides courtesy of Charles Leiserson with small changes by Carola Wenk



Paths in graphs

Consider a digraph $G = (V, E)$ with edge-weight function $w : E \rightarrow \mathbb{R}$. The **weight** of path $p = v_1 \rightarrow v_2 \rightarrow \dots \rightarrow v_k$ is defined to be

$$w(p) = \sum_{i=1}^{k-1} w(v_i, v_{i+1}).$$

Example:

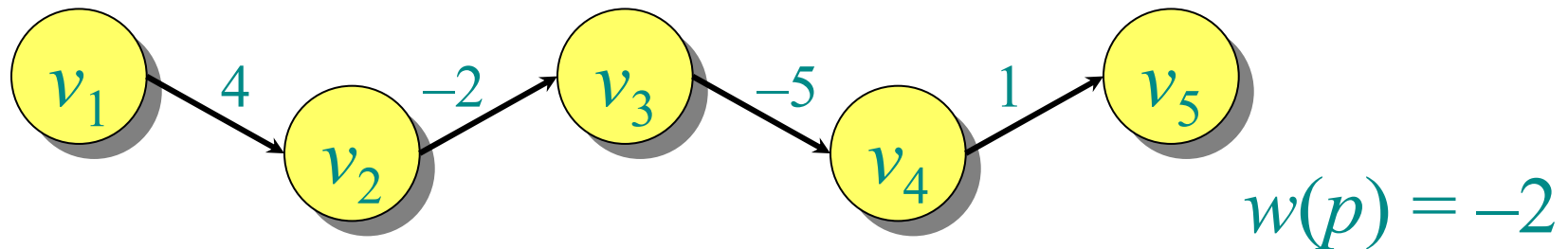



Shortest paths

A *shortest path* from u to v is a path of minimum weight from u to v . The *shortest-path weight* from u to v is defined as

$$\delta(u, v) = \min\{w(p) : p \text{ is a path from } u \text{ to } v\}.$$

Note: $\delta(u, v) = \infty$ if no path from u to v exists.

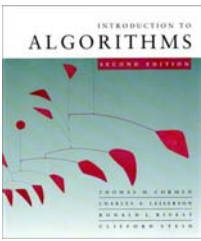

Optimal substructure

Theorem. A subpath of a shortest path is a shortest path.

Proof. Cut and paste:

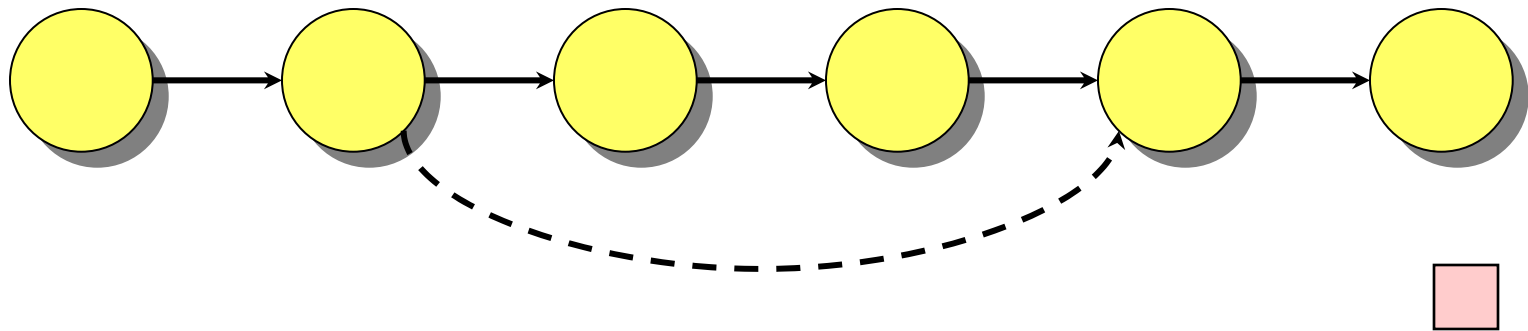



Triangle inequality

Theorem. For all $u, v, x \in V$, we have
$$\delta(u, v) \leq \delta(u, x) + \delta(x, v).$$

Proof.

- $\delta(u, v)$ minimizes over **all** paths from u to v
- Concatenating two shortest paths from u to x and from x to v yields **one** specific path from u to v

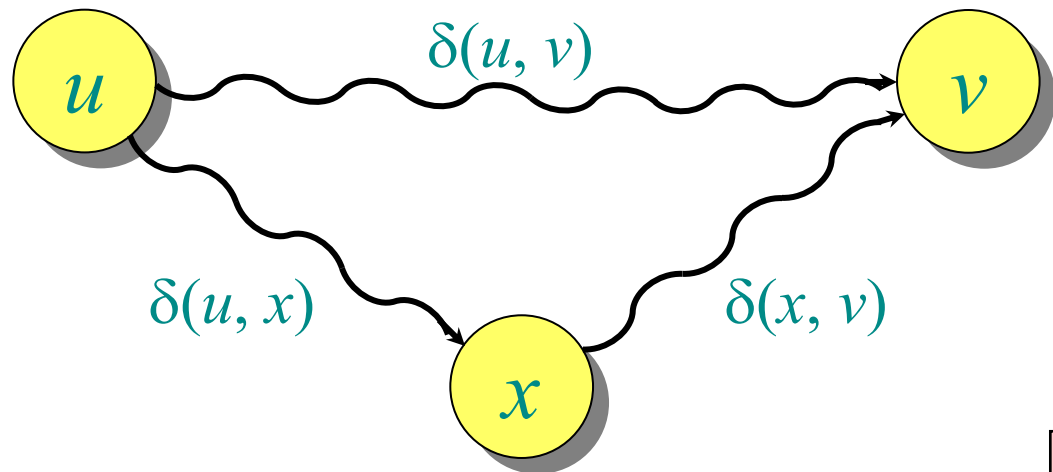

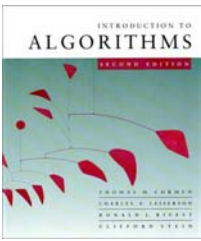

Well-definedness of shortest paths

If a graph G contains a negative-weight cycle, then some shortest paths may not exist.

Example:

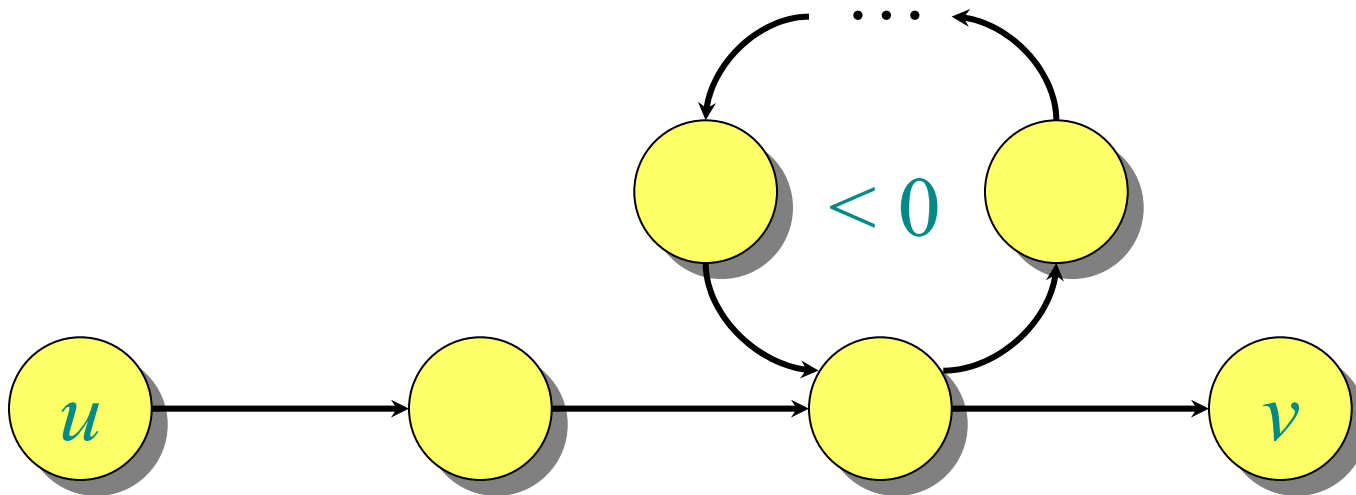



Single-source shortest paths

Problem. From a given source vertex $s \in V$, find the shortest-path weights $\delta(s, v)$ for all $v \in V$.

If all edge weights $w(u, v)$ are *nonnegative*, all shortest-path weights must exist.

IDEA: Greedy.

1. Maintain a set S of vertices whose shortest-path weights from s are known.
2. At each step add to S the vertex $v \in V - S$ whose distance estimate from s is minimal.
3. Update the distance estimates of vertices adjacent to v .

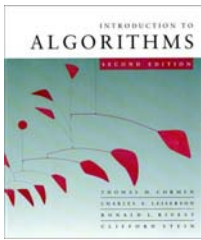

Dijkstra's algorithm

$d[s] \leftarrow 0$

for each $v \in V - \{s\}$

do $d[v] \leftarrow \infty$

$S \leftarrow \emptyset$

$Q \leftarrow V$ \triangleright Q is a priority queue maintaining $V - S$

while $Q \neq \emptyset$ **do**

$u \leftarrow \text{EXTRACT-MIN}(Q)$

$S \leftarrow S \cup \{u\}$

for each $v \in \text{Adj}[u]$ **do**

if $d[v] > d[u] + w(u, v)$ **then**

$d[v] \leftarrow d[u] + w(u, v)$

*relaxation
step*

↑
Implicit DECREASE-KEY



Dijkstra

$d[s] \leftarrow 0$
for each $v \in V - \{s\}$
 do $d[v] \leftarrow \infty$
 $S \leftarrow \emptyset$
 $Q \leftarrow V$ ▷ Q is
while $Q \neq \emptyset$ **do**

$u \leftarrow \text{EXTRACT-MIN}(Q)$
 $S \leftarrow S \cup \{u\}$
for each $v \in \text{Adj}[u]$ **do**

if $d[v] > d[u] + w(u, v)$ **then**
 $d[v] \leftarrow d[u] + w(u, v)$

↑
 Implicit DECREASE-KEY

PRIM's algorithm
 $Q \leftarrow V$
 $key[v] \leftarrow \infty$ for all $v \in V$
 $key[s] \leftarrow 0$ for some arbitrary $s \in V$
while $Q \neq \emptyset$
 do $u \leftarrow \text{EXTRACT-MIN}(Q)$
 for each $v \in \text{Adj}[u]$
 do if $v \in Q$ and $w(u, v) < key[v]$
 then $key[v] \leftarrow w(u, v)$
 $\pi[v] \leftarrow u$

It suffices to only check $v \in Q$, but it doesn't hurt to check all v

relaxation step



Example of Dijkstra's algorithm

Graph with nonnegative edge weights:

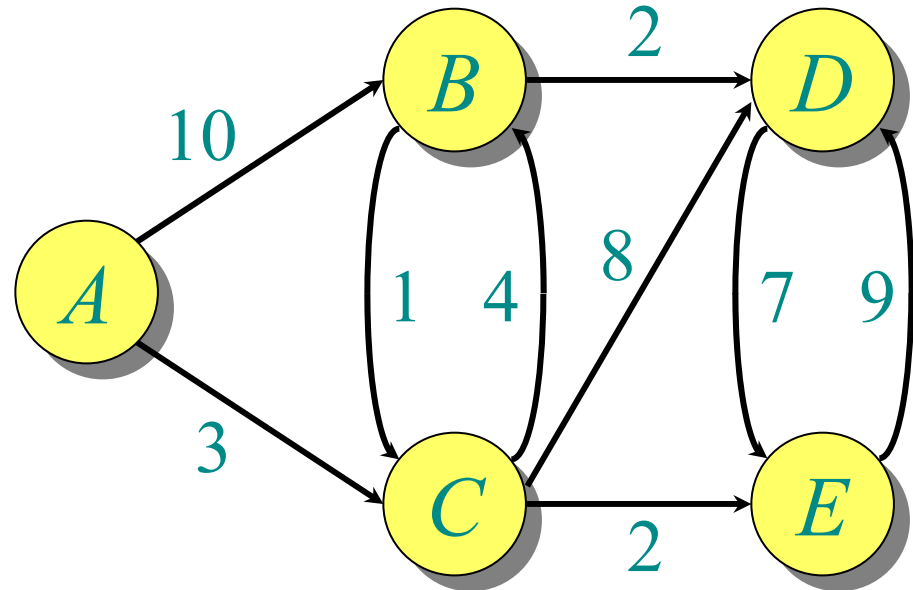

```
while  $Q \neq \emptyset$  do
   $u \leftarrow \text{EXTRACT-MIN}(Q)$ 
   $S \leftarrow S \cup \{u\}$ 
  for each  $v \in \text{Adj}[u]$  do
    if  $d[v] > d[u] + w(u, v)$  then
       $d[v] \leftarrow d[u] + w(u, v)$ 
```



Example of Dijkstra's algorithm

Initialize:

$S: \{\}$

$Q:$

A	B	C	D	E
0	∞	∞	∞	∞

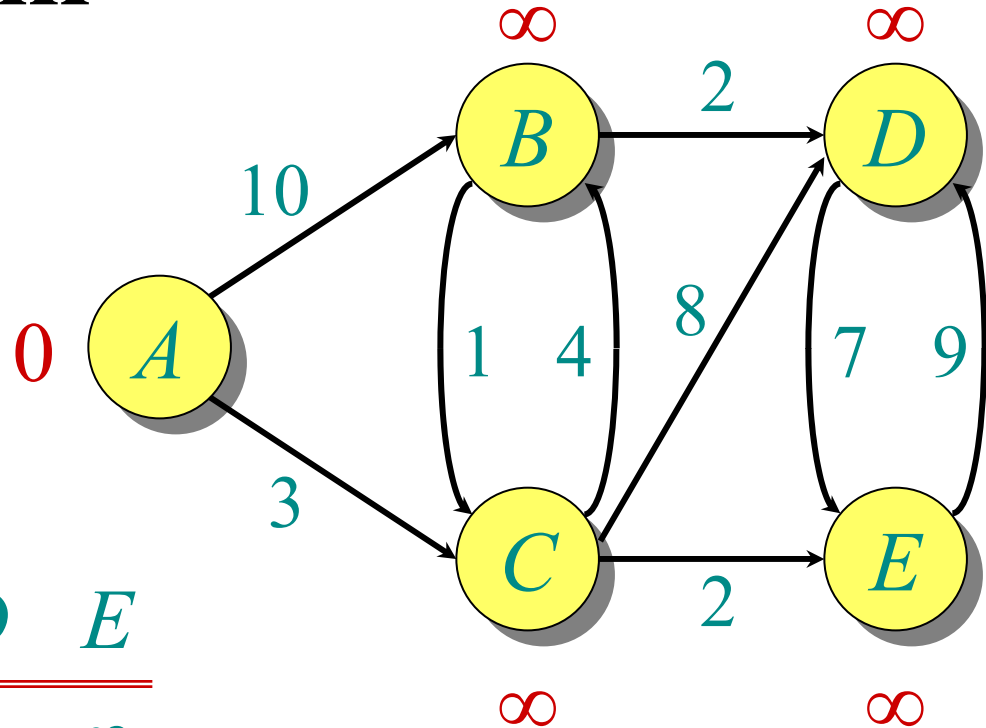

```
while  $Q \neq \emptyset$  do
   $u \leftarrow \text{EXTRACT-MIN}(Q)$ 
   $S \leftarrow S \cup \{u\}$ 
  for each  $v \in \text{Adj}[u]$  do
    if  $d[v] > d[u] + w(u, v)$  then
       $d[v] \leftarrow d[u] + w(u, v)$ 
```

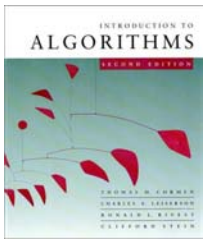

Example of Dijkstra's algorithm

“A” ← **EXTRACT-MIN**(Q):

S: { A }

Q:	A	B	C	D	E
	0	∞	∞	∞	∞

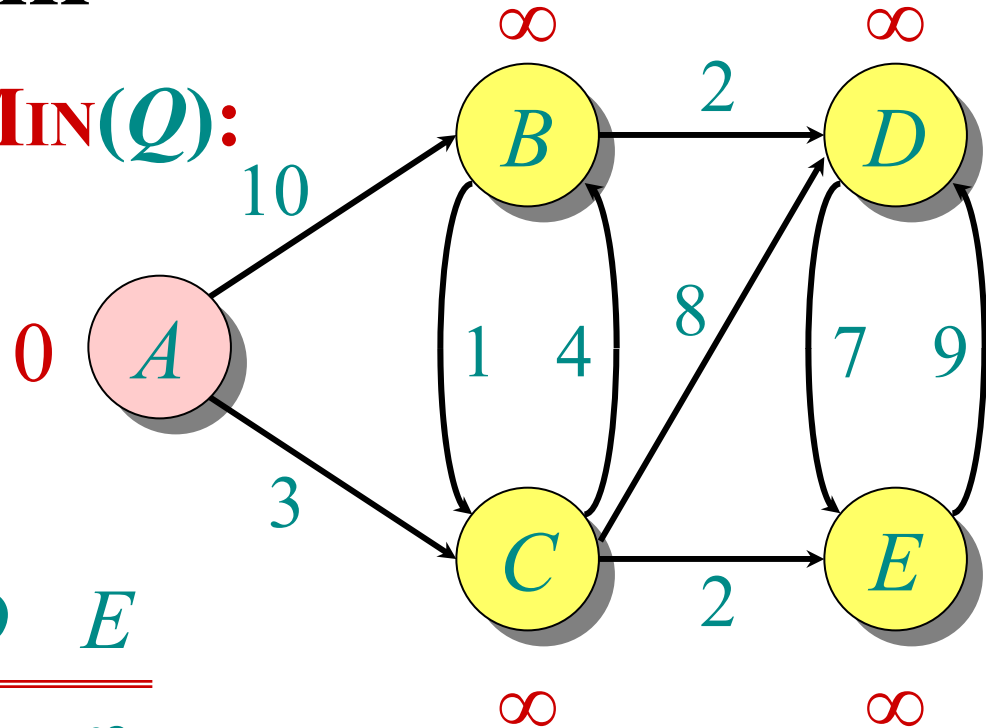

```
while  $Q \neq \emptyset$  do
   $u \leftarrow \text{EXTRACT-MIN}(Q)$ 
   $S \leftarrow S \cup \{u\}$ 
  for each  $v \in \text{Adj}[u]$  do
    if  $d[v] > d[u] + w(u, v)$  then
       $d[v] \leftarrow d[u] + w(u, v)$ 
```



Example of Dijkstra's algorithm

Relax all edges leaving A :

$S: \{A\}$

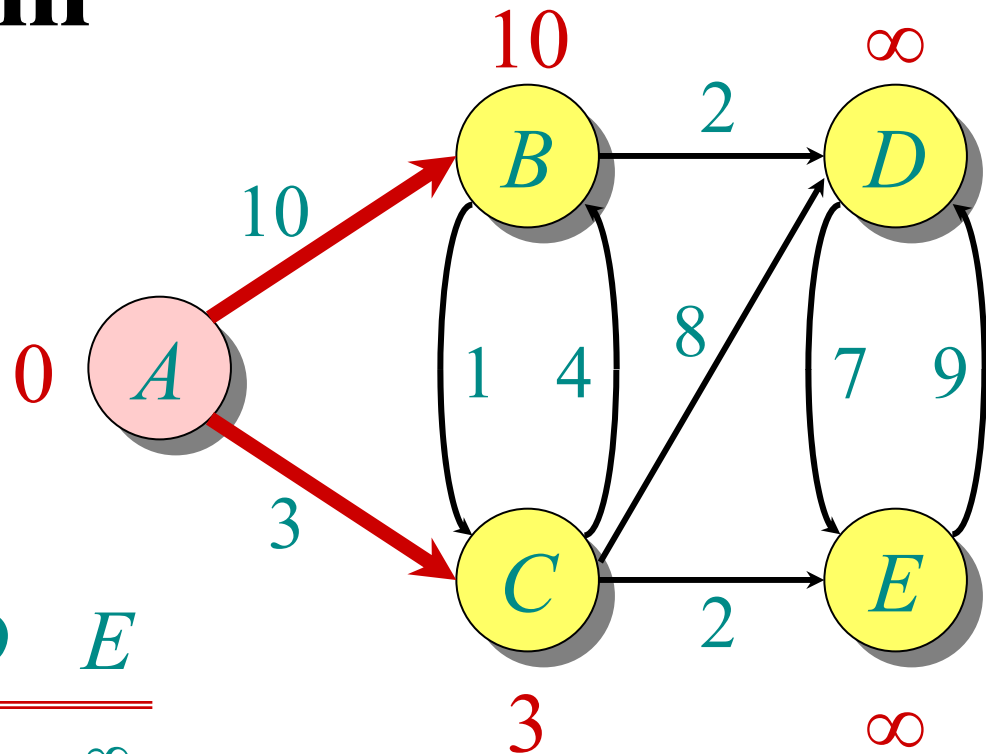

$Q:$

A	B	C	D	E
0	∞	∞	∞	∞
	10	3	-	-

```
while  $Q \neq \emptyset$  do
   $u \leftarrow \text{EXTRACT-MIN}(Q)$ 
   $S \leftarrow S \cup \{u\}$ 
  for each  $v \in \text{Adj}[u]$  do
    if  $d[v] > d[u] + w(u, v)$  then
       $d[v] \leftarrow d[u] + w(u, v)$ 
```

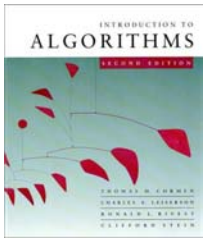

Example of Dijkstra's algorithm

“C” ← EXTRACT-MIN(Q):

S: { A, C }

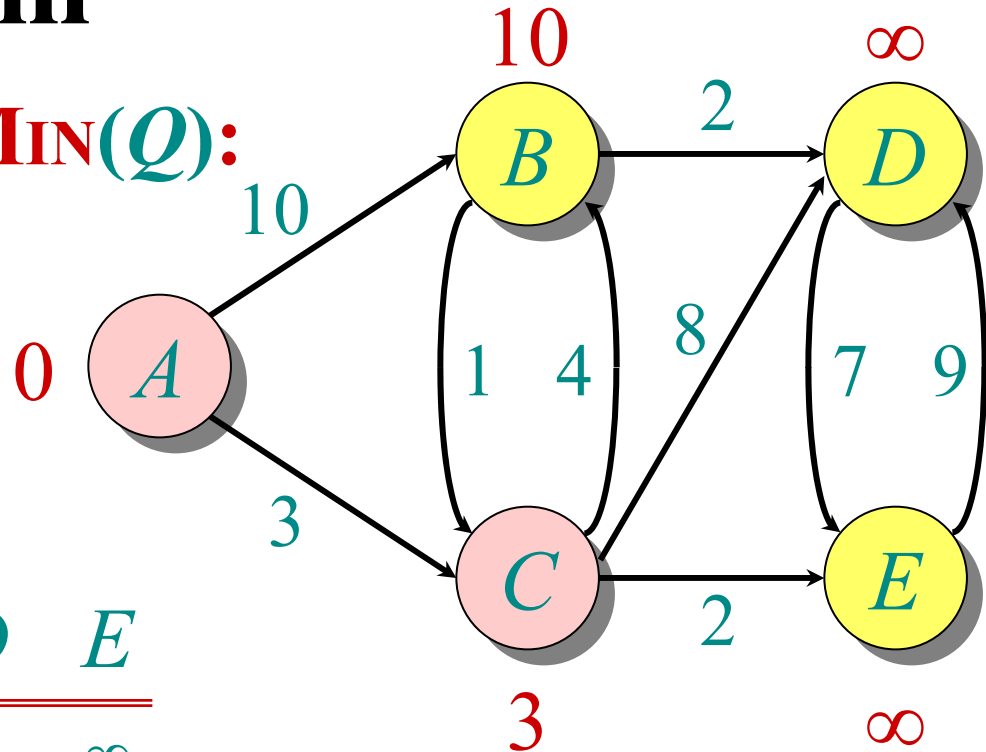

Q:	A	B	C	D	E
	0	∞	∞	∞	∞
		10	3	–	–

```

while Q ≠ ∅ do
  u ← EXTRACT-MIN(Q)
  S ← S ∪ {u}
  for each v ∈ Adj[u] do
    if d[v] > d[u] + w(u, v) then
      d[v] ← d[u] + w(u, v)
  
```



Example of Dijkstra's algorithm

Relax all edges leaving C :

$S: \{A, C\}$

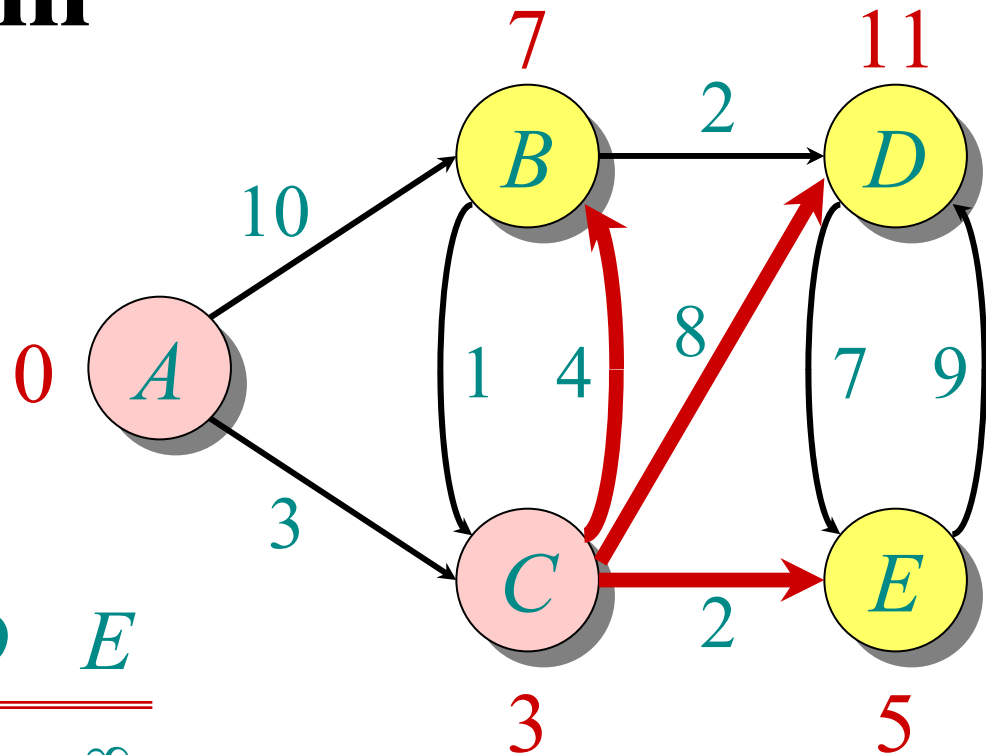

$Q:$

A	B	C	D	E
0	∞	∞	∞	∞
	10	3	—	—
	7		11	5

```

while  $Q \neq \emptyset$  do
   $u \leftarrow \text{EXTRACT-MIN}(Q)$ 
   $S \leftarrow S \cup \{u\}$ 
  for each  $v \in \text{Adj}[u]$  do
    if  $d[v] > d[u] + w(u, v)$  then
       $d[v] \leftarrow d[u] + w(u, v)$ 
  
```



Example of Dijkstra's algorithm

“E” ← **EXTRACT-MIN**(Q):

S: { A, C, E }

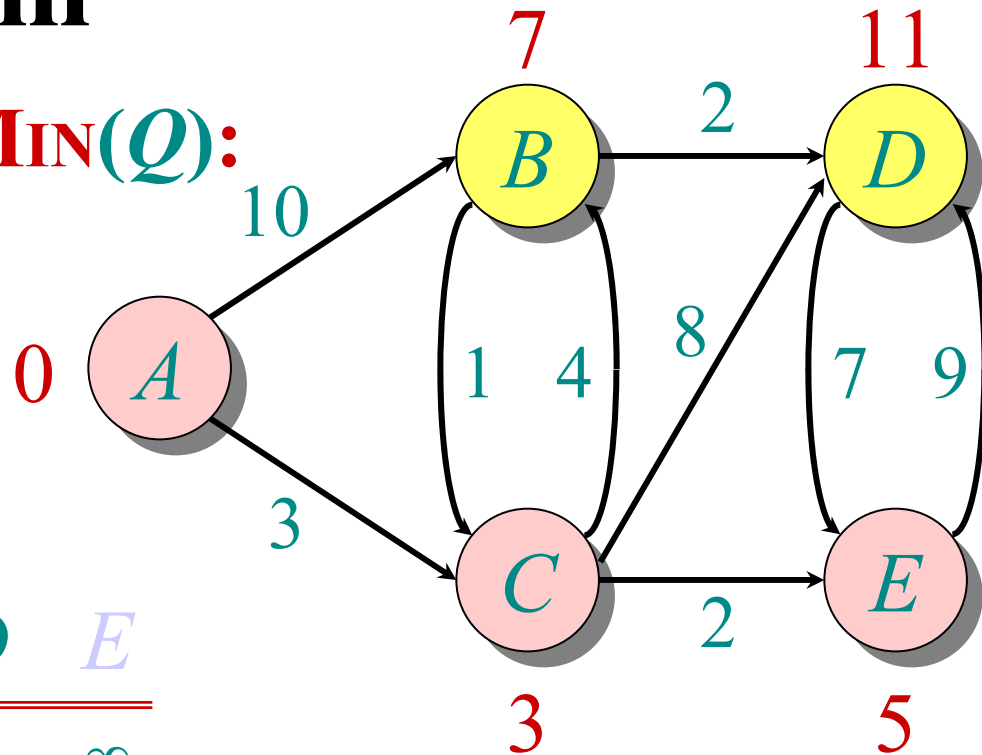

Q:	A	B	C	D	E
	0	∞	∞	∞	∞
		10	3	–	–
		7		11	5

```

while Q ≠ ∅ do
  u ← EXTRACT-MIN(Q)
  S ← S ∪ {u}
  for each v ∈ Adj[u] do
    if d[v] > d[u] + w(u, v) then
      d[v] ← d[u] + w(u, v)
  
```



Example of Dijkstra's algorithm

Relax all edges leaving E :

$S: \{A, C, E\}$

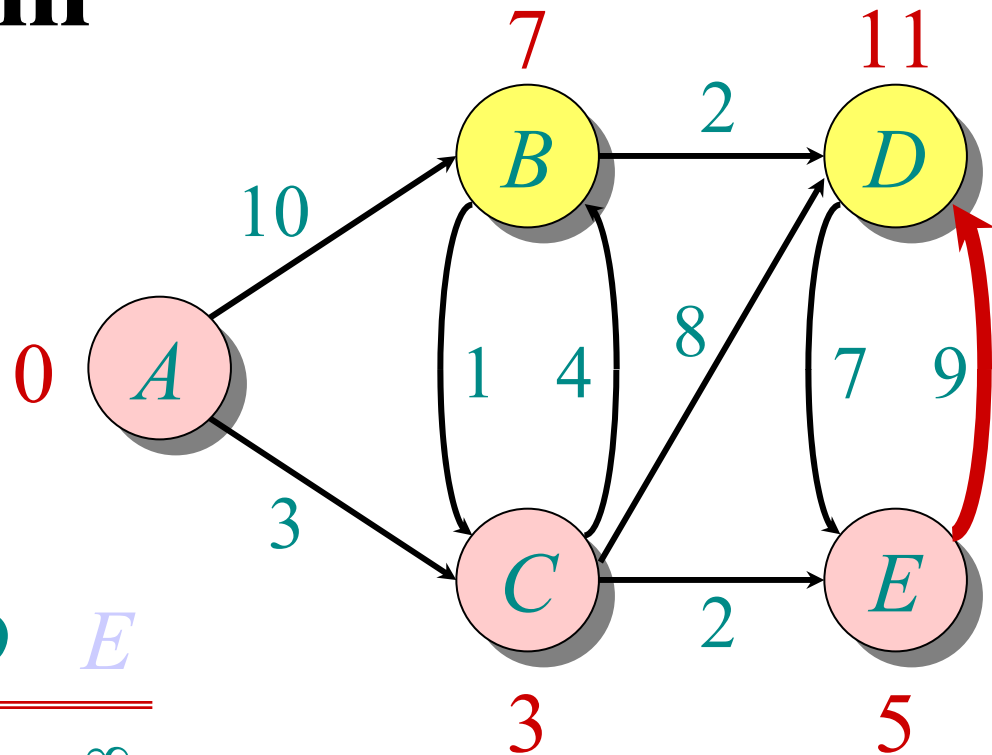

$Q:$

A	B	C	D	E
0	∞	∞	∞	∞
	10	3	∞	∞
	7		11	5
	7		11	

```

while  $Q \neq \emptyset$  do
   $u \leftarrow \text{EXTRACT-MIN}(Q)$ 
   $S \leftarrow S \cup \{u\}$ 
  for each  $v \in \text{Adj}[u]$  do
    if  $d[v] > d[u] + w(u, v)$  then
       $d[v] \leftarrow d[u] + w(u, v)$ 
  
```

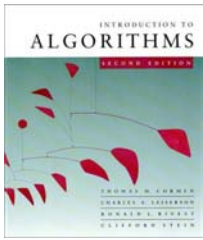

Example of Dijkstra's algorithm

“B” ← EXTRACT-MIN(Q):

S: { A, C, E, B } 0

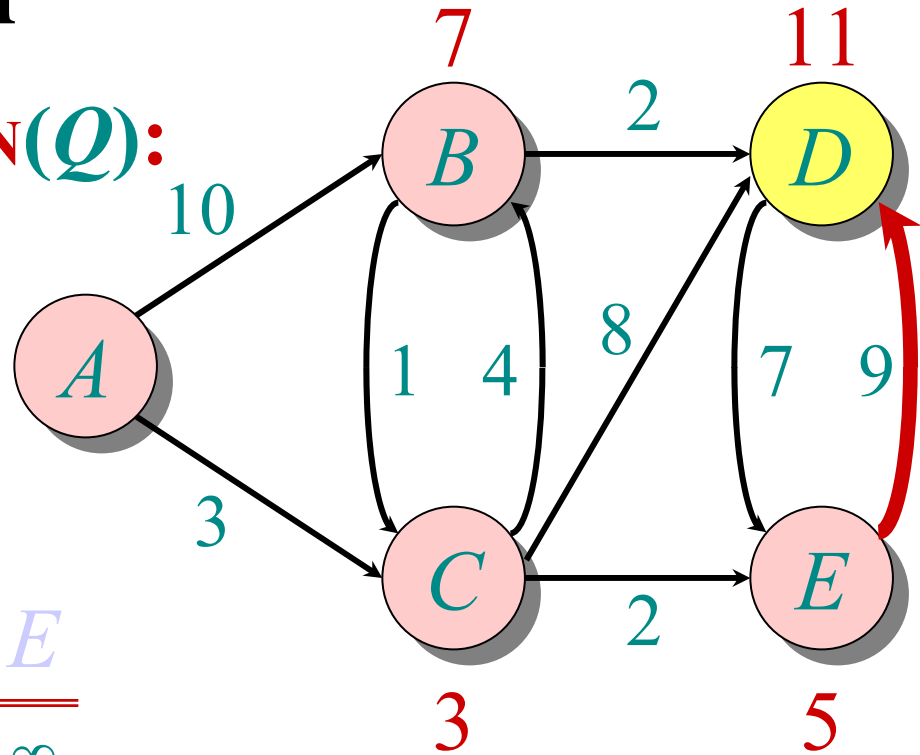

Q:	A	B	C	D	E
	0	∞	∞	∞	∞
		10	3	∞	∞
		7		11	5
		7		11	

```

while Q ≠ ∅ do
  u ← EXTRACT-MIN(Q)
  S ← S ∪ {u}
  for each v ∈ Adj[u] do
    if d[v] > d[u] + w(u, v) then
      d[v] ← d[u] + w(u, v)
  
```



Example of Dijkstra's algorithm

Relax all edges leaving B :

$S: \{A, C, E, B\}$ 0

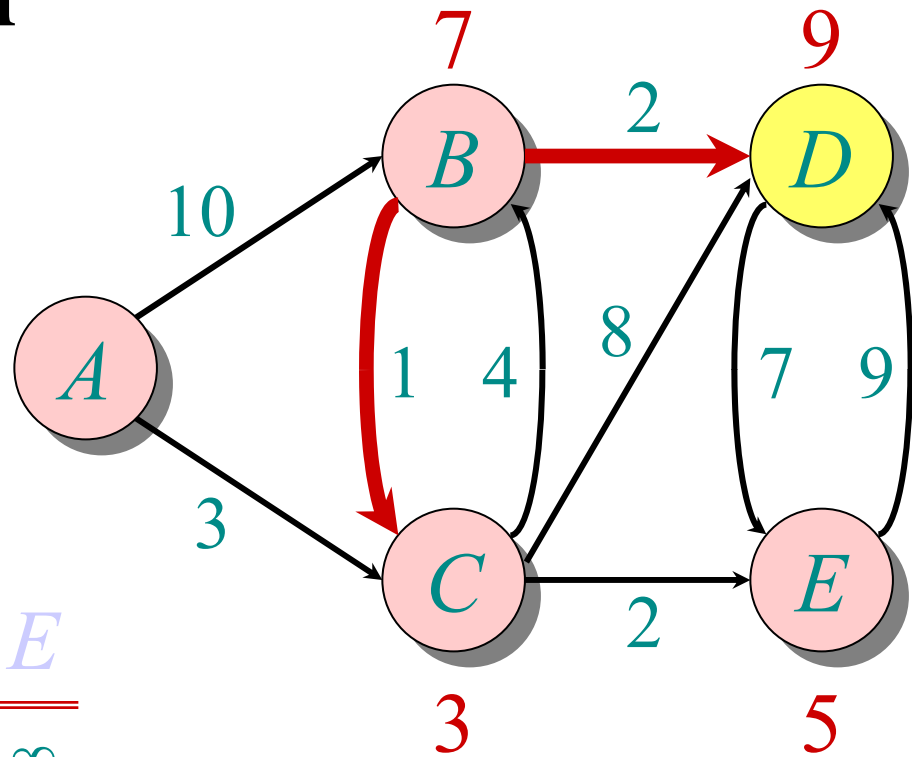

$Q:$

A	B	C	D	E
0	∞	∞	∞	∞
10	3	∞	∞	∞
7		11	5	
7		11		
		9		

```

while  $Q \neq \emptyset$  do
   $u \leftarrow \text{EXTRACT-MIN}(Q)$ 
   $S \leftarrow S \cup \{u\}$ 
  for each  $v \in \text{Adj}[u]$  do
    if  $d[v] > d[u] + w(u, v)$  then
       $d[v] \leftarrow d[u] + w(u, v)$ 
  
```



Example of Dijkstra's algorithm

“D” ← **EXTRACT-MIN**(Q):

S: { A, C, E, B, D } 0

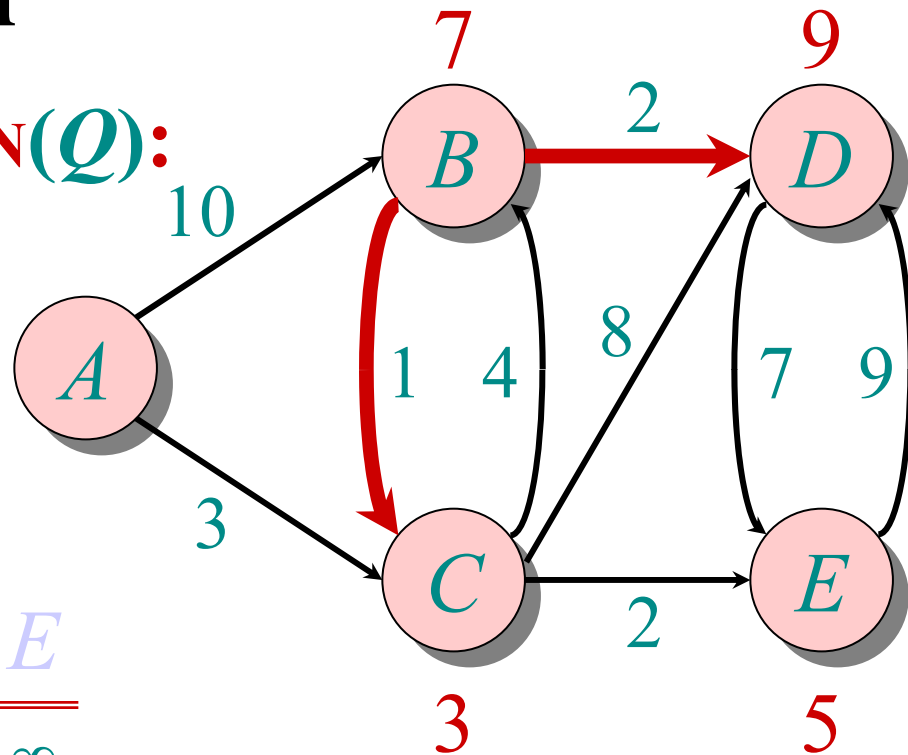

Q:

A	B	C	D	E
0	∞	∞	∞	∞
10	3	∞	∞	∞
7		11	5	
7		11		
		9		

```

while Q ≠ ∅ do
  u ← EXTRACT-MIN(Q)
  S ← S ∪ {u}
  for each v ∈ Adj[u] do
    if d[v] > d[u] + w(u, v) then
      d[v] ← d[u] + w(u, v)
  
```

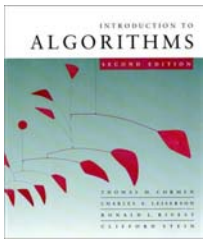

Analysis of Dijkstra

$|V|$ times { $degree(u)$ times { while $Q \neq \emptyset$ do
 $u \leftarrow \text{EXTRACT-MIN}(Q)$
 $S \leftarrow S \cup \{u\}$
 for each $v \in \text{Adj}[u]$ do
 if $d[v] > d[u] + w(u, v)$ then
 $d[v] \leftarrow d[u] + w(u, v)$

Handshaking Lemma $\Rightarrow \Theta(|E|)$ implicit DECREASE-KEY's.

Time = $\Theta(|V|) \cdot T_{\text{EXTRACT-MIN}} + \Theta(|E|) \cdot T_{\text{DECREASE-KEY}}$

Note: Same formula as in the analysis of Prim's minimum spanning tree algorithm.

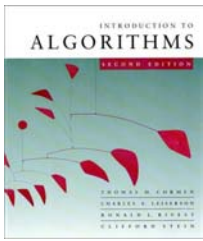

Analysis of Dijkstra (continued)

$$\text{Time} = \Theta(|V|) \cdot T_{\text{EXTRACT-MIN}} + \Theta(|E|) \cdot T_{\text{DECREASE-KEY}}$$

Q	$T_{\text{EXTRACT-MIN}}$	$T_{\text{DECREASE-KEY}}$	Total
-----	--------------------------	---------------------------	-------

array	$O(V)$	$O(1)$	$O(V ^2)$
-------	----------	--------	------------

binary heap	$O(\log V)$	$O(\log V)$	$O(E \log V)$
-------------	---------------	---------------	-------------------

Fibonacci heap	$O(\log V)$ amortized	$O(1)$ amortized	$O(E + V \log V)$ worst case
----------------	-------------------------	------------------	------------------------------------

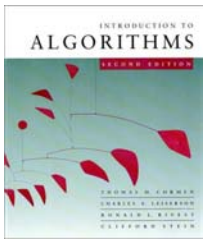

Correctness

Theorem. (i) For all $v \in S$: $d[v] = \delta(s, v)$
(ii) For all $v \notin S$: $d[v] =$ weight of shortest path from s to v that uses only (besides v itself) vertices in S .

Corollary. Dijkstra's algorithm terminates with $d[v] = \delta(s, v)$ for all $v \in V$.

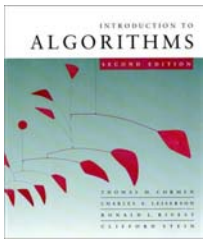

Correctness

Theorem. (i) For all $v \in S$: $d[v] = \delta(s, v)$
(ii) For all $v \notin S$: $d[v] =$ weight of shortest path from s to v that uses only (besides v itself) vertices in S .

Proof. By induction.

- Base: Before the while loop, $d[s]=0$ and $d[v]=\infty$ for all $v \neq s$, so (i) and (ii) are true.
- Step: Assume (i) and (ii) are true before an iteration; now we need to show they remain true after another iteration. Let u be the vertex added to S , so $d[u] \leq d[v]$ for all other $v \notin S$.

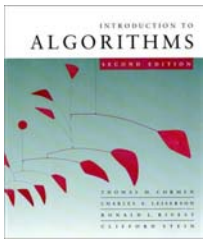

Correctness

Theorem. (i) For all $v \in S$: $d[v] = \delta(s, v)$
(ii) For all $v \notin S$: $d[v] =$ weight of shortest path from s to v that uses only (besides v itself) vertices in S .

- (i) Need to show that $d[u] = \delta(s, u)$. Assume the contrary.
 \Rightarrow There is a path p from s to u with $w(p) < d[u]$. Because of (ii) that path uses vertices $\notin S$, in addition to u .
 \Rightarrow Let y be first vertex on p such that $y \notin S$.

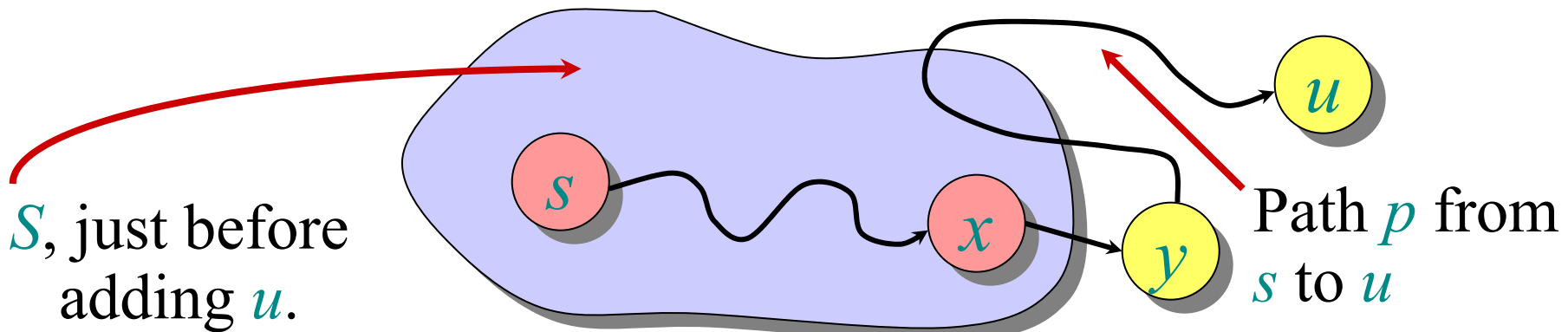

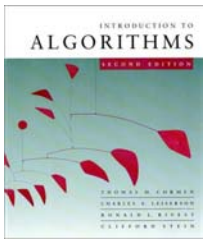

Correctness

- Theorem.** (i) For all $v \in S$: $d[v] = \delta(s, v)$
(ii) For all $v \notin S$: $d[v] =$ weight of shortest path from s to v that uses only (besides v itself) vertices in S .
-

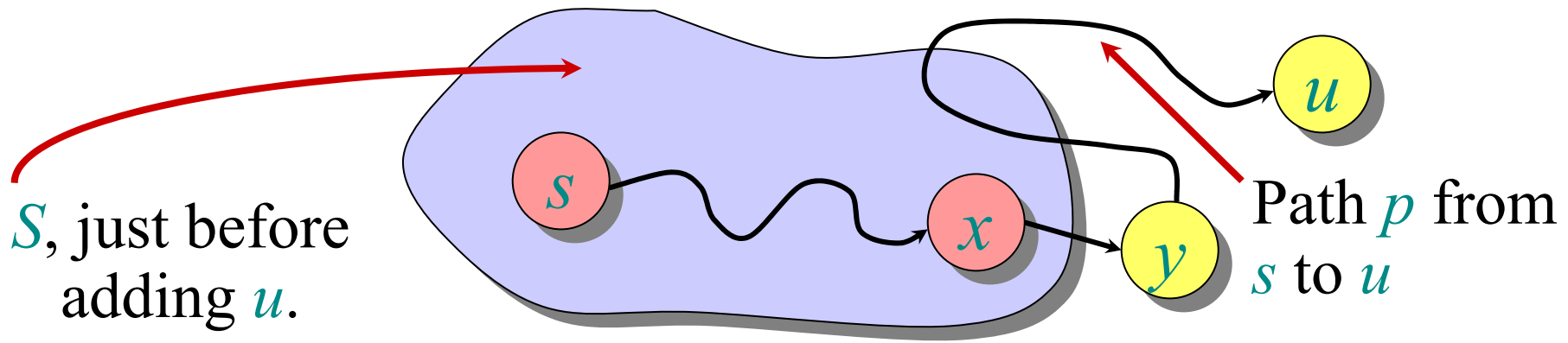

$\Rightarrow d[y] \leq w(p) < d[u]$. Contradiction to the choice of u .

weights are nonnegative

assumption about path

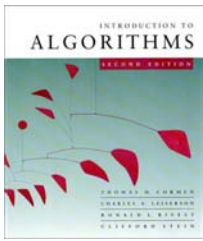

Correctness

Theorem. (i) For all $v \in S$: $d[v] = \delta(s, v)$
(ii) For all $v \notin S$: $d[v] =$ weight of shortest path from s to v that uses only (besides v itself) vertices in S .

- (ii) Let $v \notin S$. Let p be a shortest path from s to v that uses only (besides v itself) vertices in S .
 - p does not contain u : (ii) true by inductive hypothesis
 - p contains u : p consists of vertices in $S \setminus \{u\}$ and ends with an edge from u to v .
 $\Rightarrow w(p) = d[u] + w(u, v)$, which is the value of $d[v]$ after adding u . So (ii) is true.



Unweighted graphs

Suppose $w(u, v) = 1$ for all $(u, v) \in E$. Can the code for Dijkstra be improved?

- Use a simple FIFO queue instead of a priority queue.
- *Breadth-first search*

```
while  $Q \neq \emptyset$ 
  do  $u \leftarrow \text{DEQUEUE}(Q)$ 
    for each  $v \in \text{Adj}[u]$ 
      do if  $d[v] = \infty$ 
          then  $d[v] \leftarrow d[u] + 1$ 
              ENQUEUE( $Q, v$ )
```

Analysis: Time = $O(|V| + |E|)$.

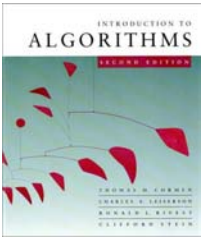

Example of breadth-first search

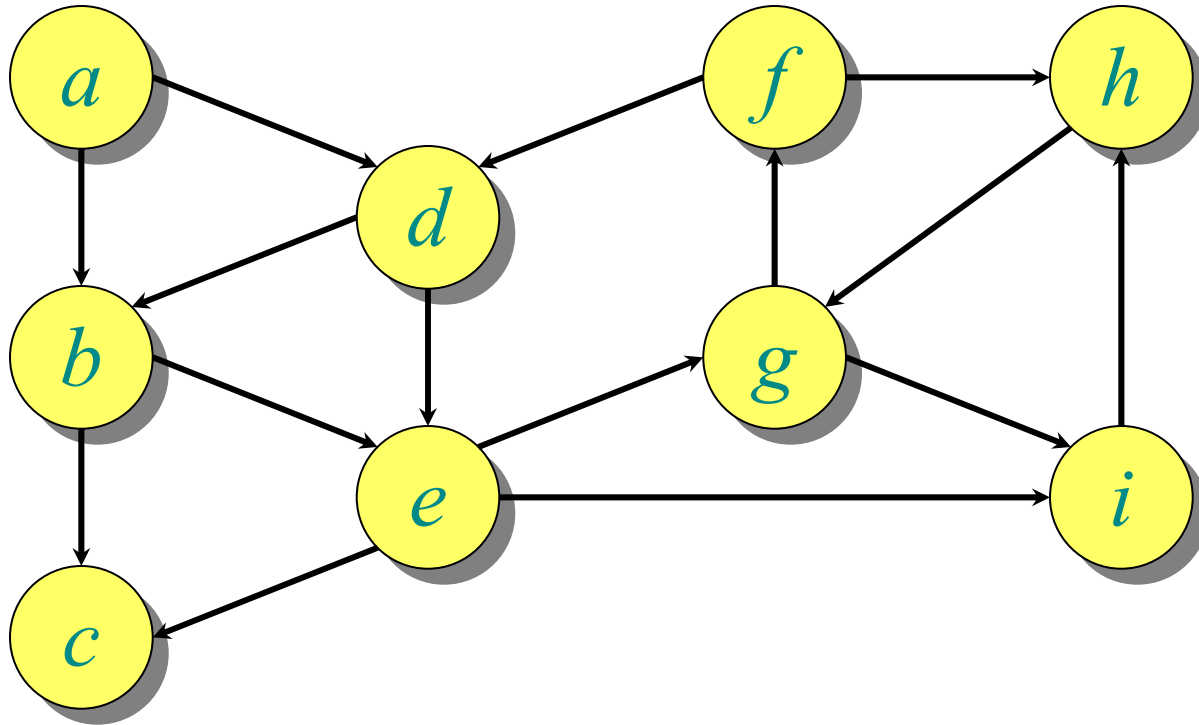

Q:

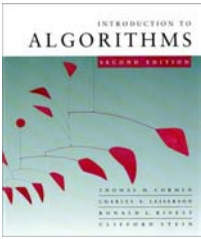

Example of breadth-first search

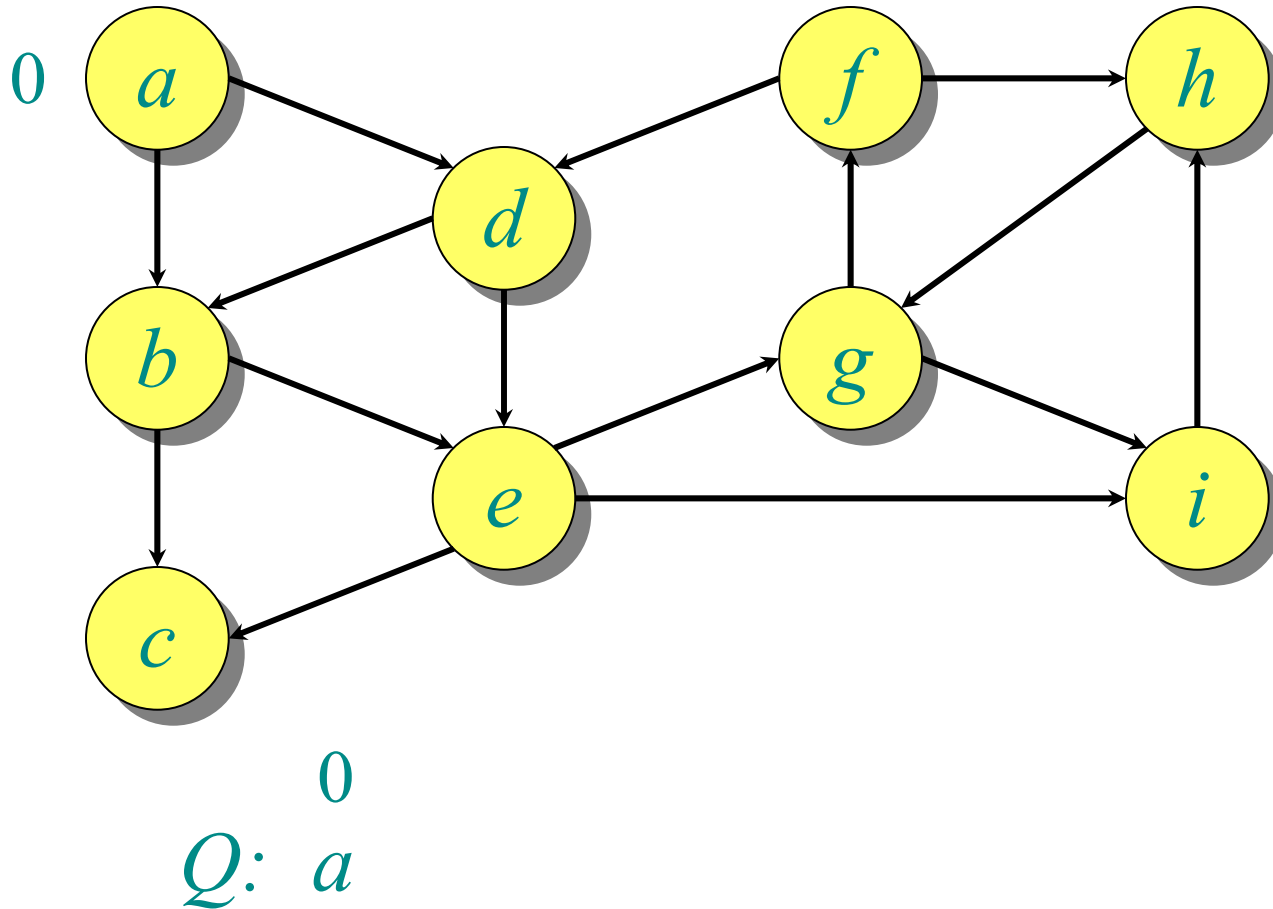

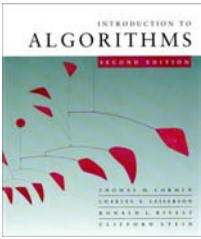

Example of breadth-first search

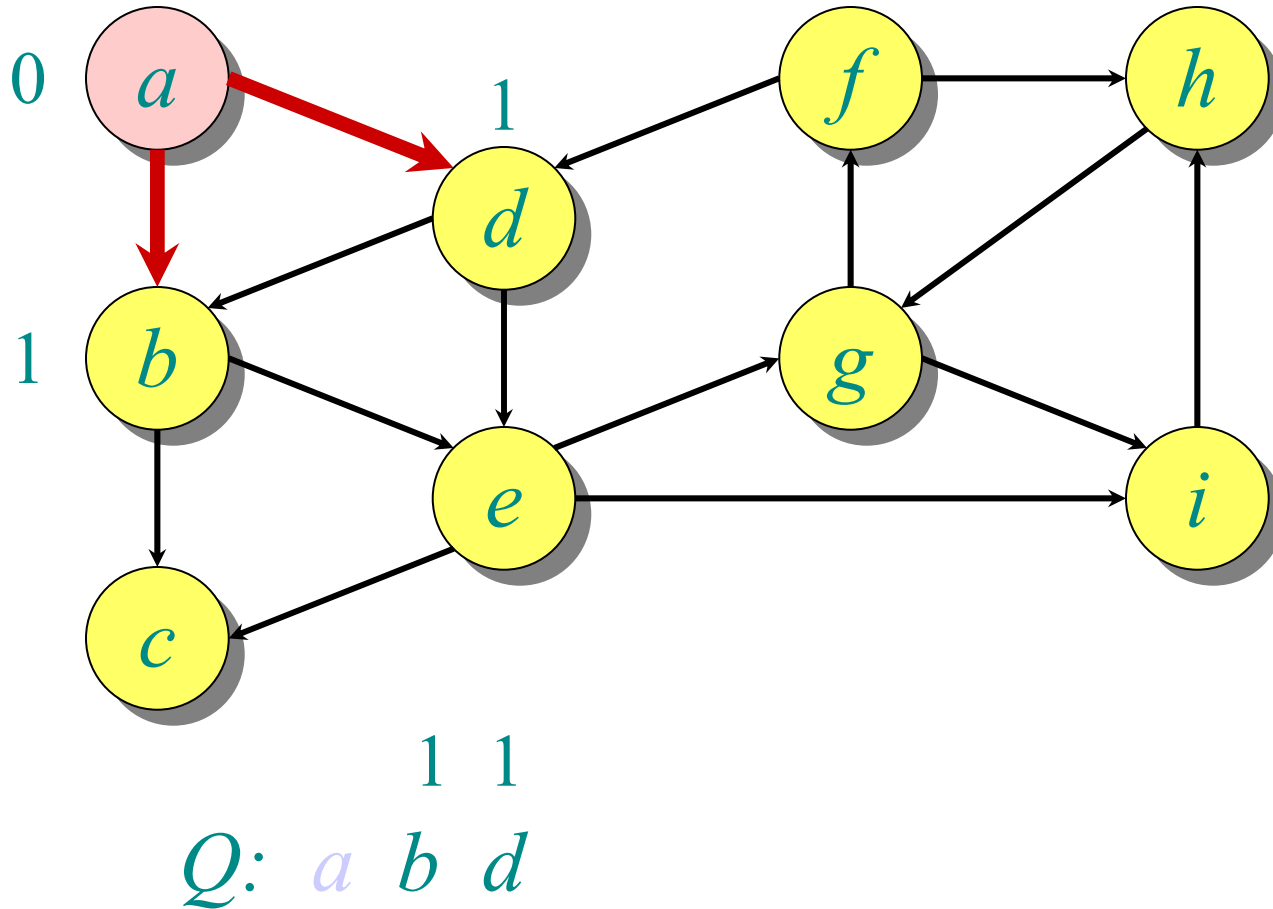

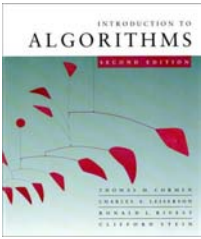

Example of breadth-first search

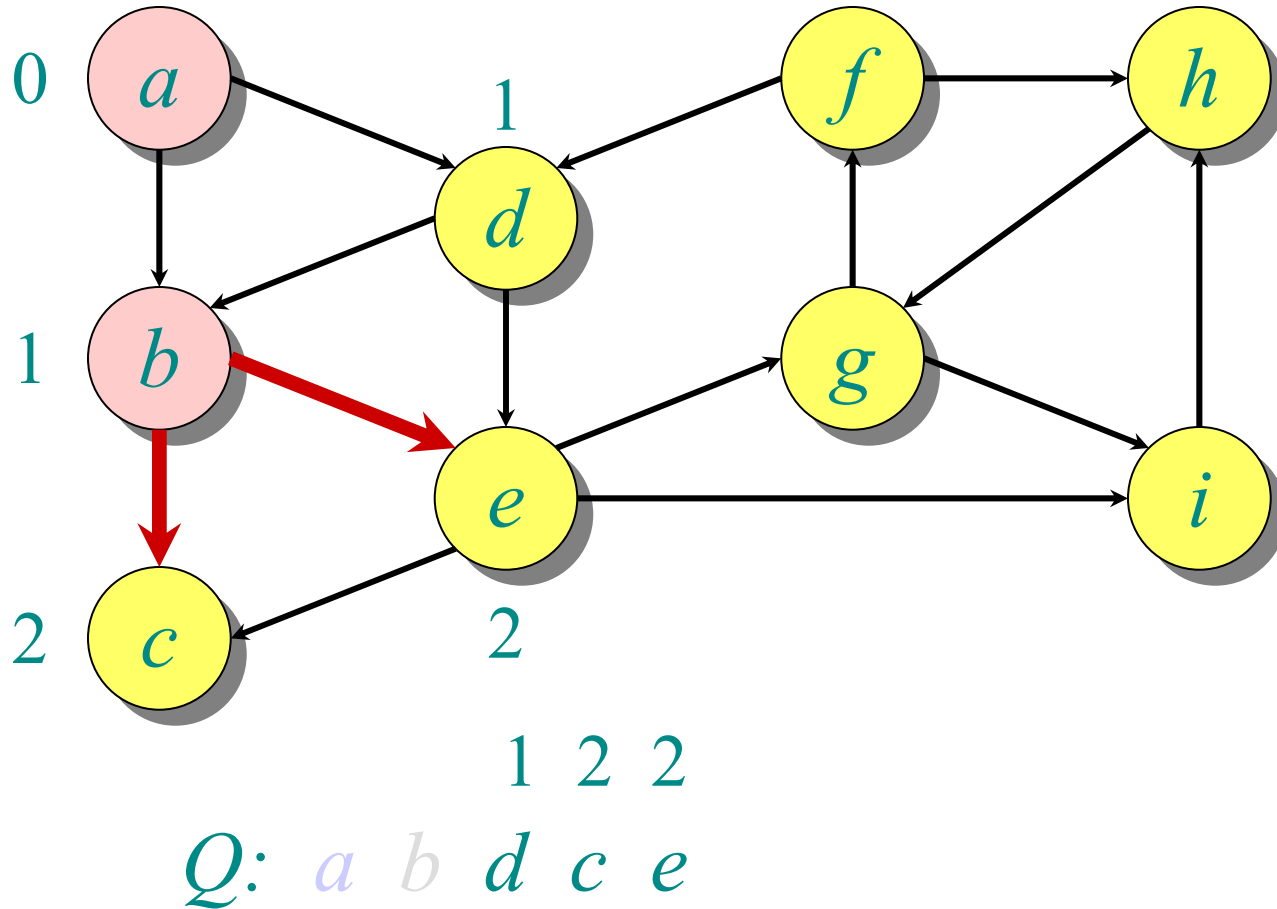

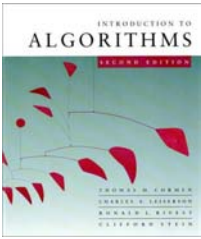

Example of breadth-first search

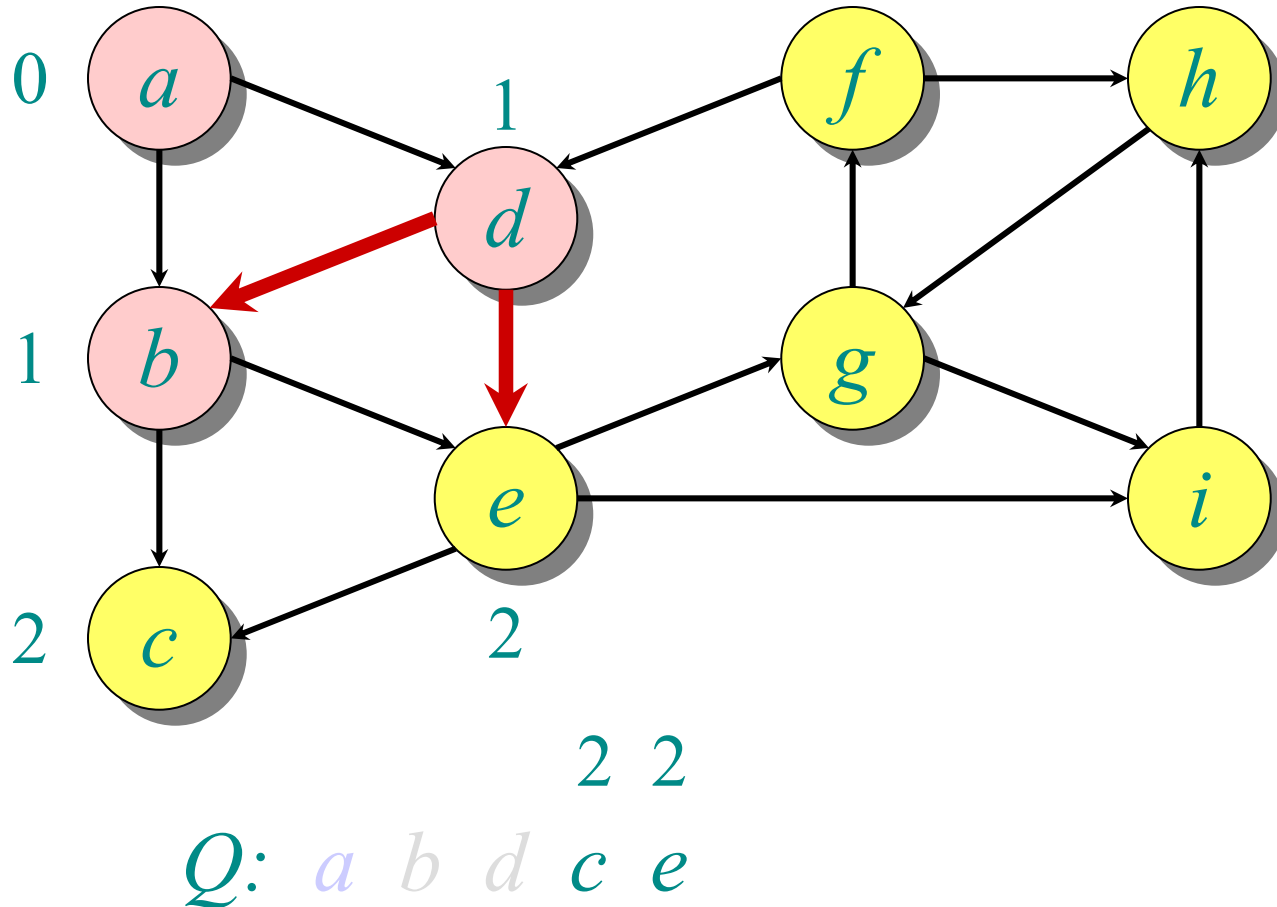

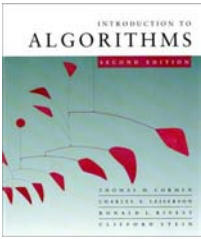

Example of breadth-first search

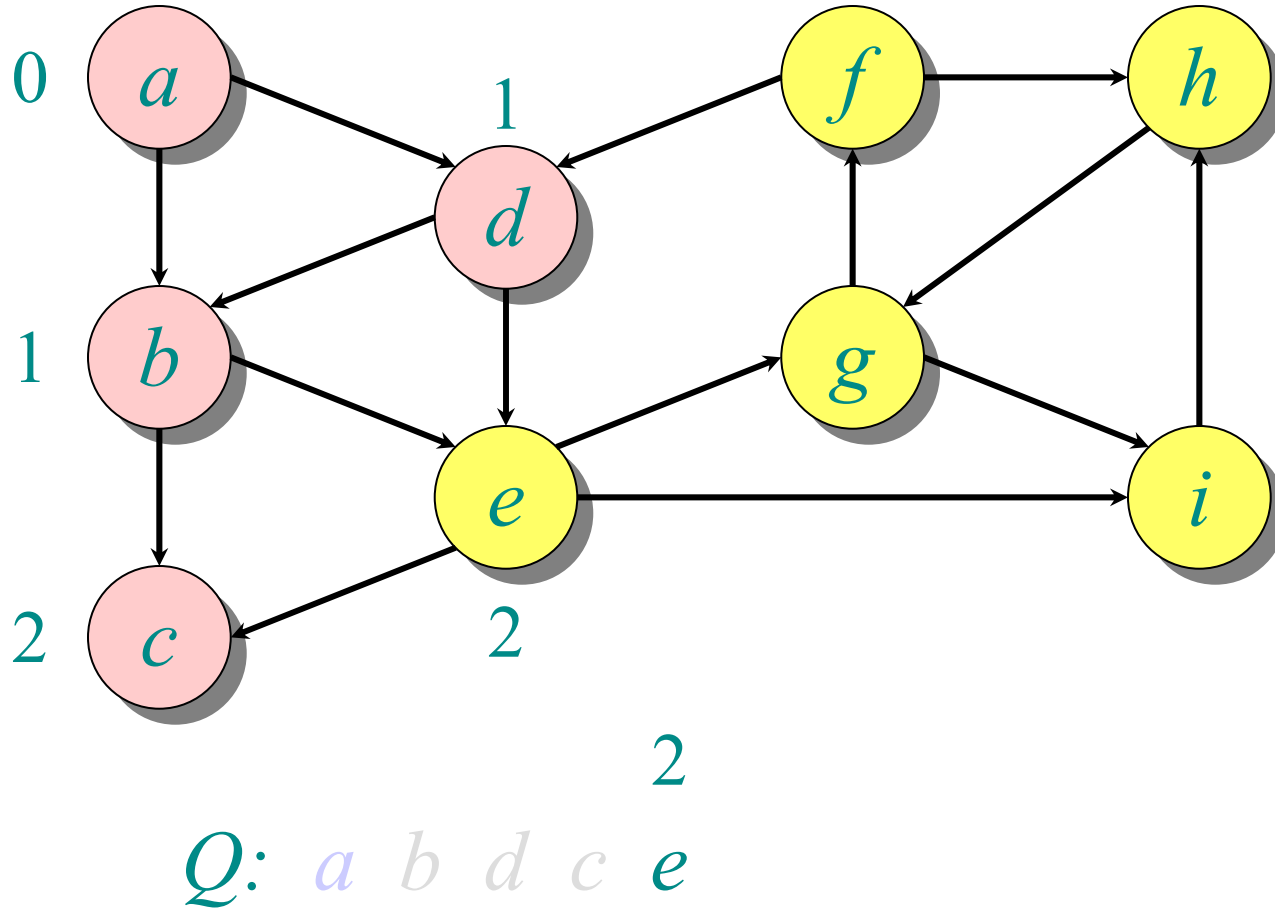

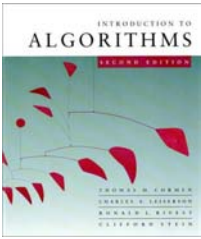

Example of breadth-first search

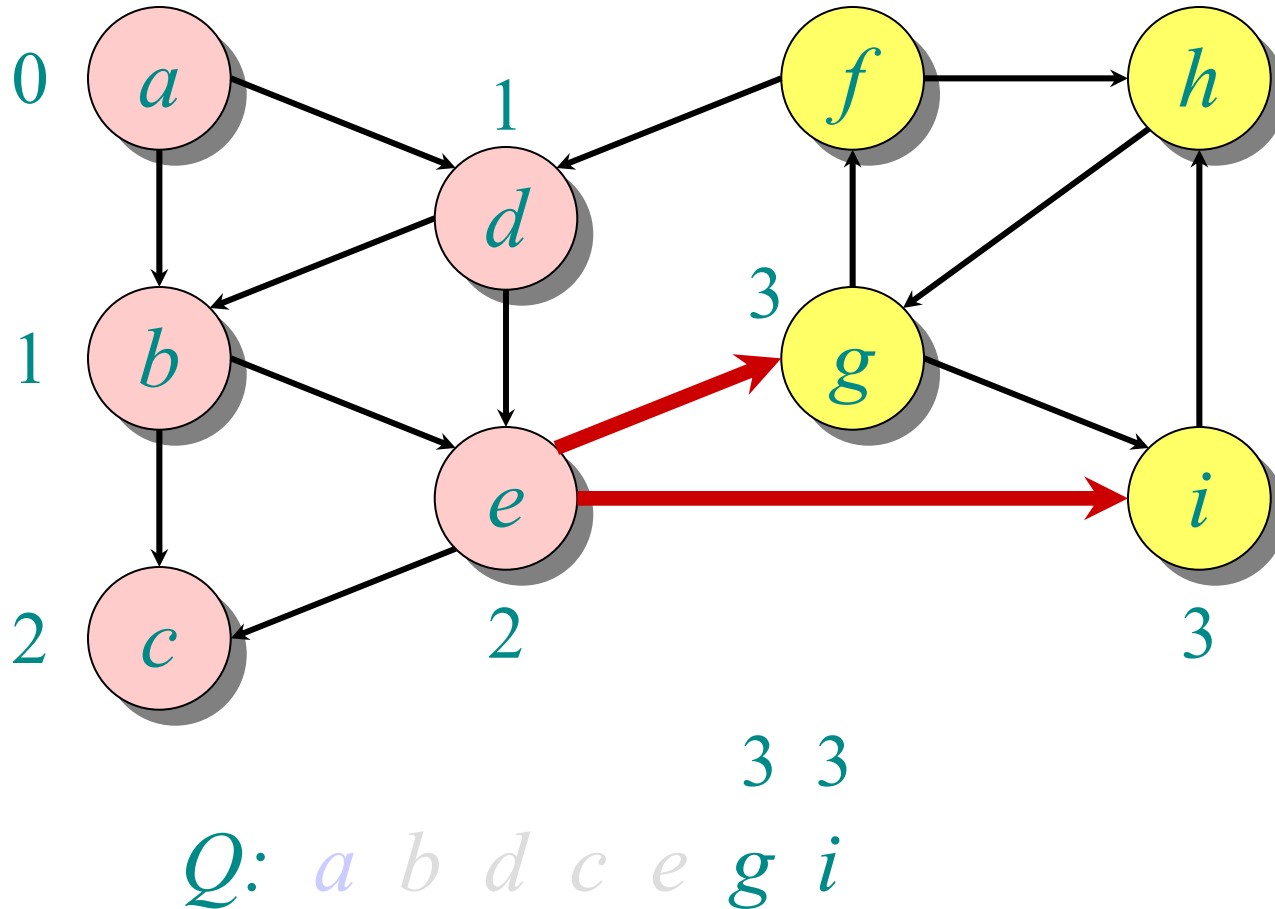

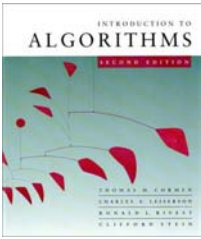

Example of breadth-first search

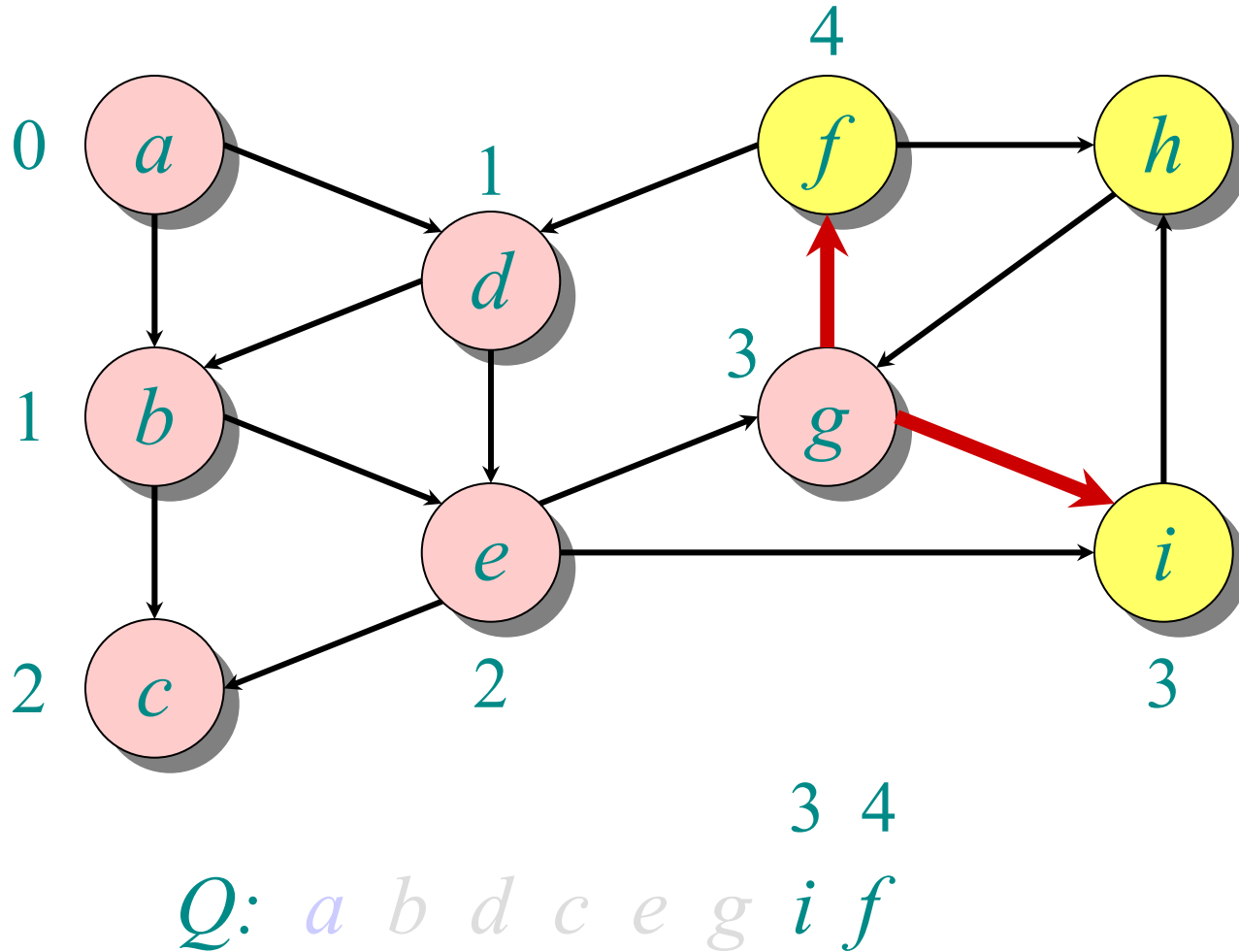

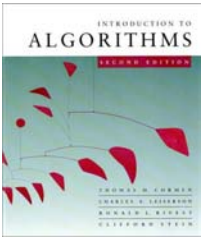

Example of breadth-first search

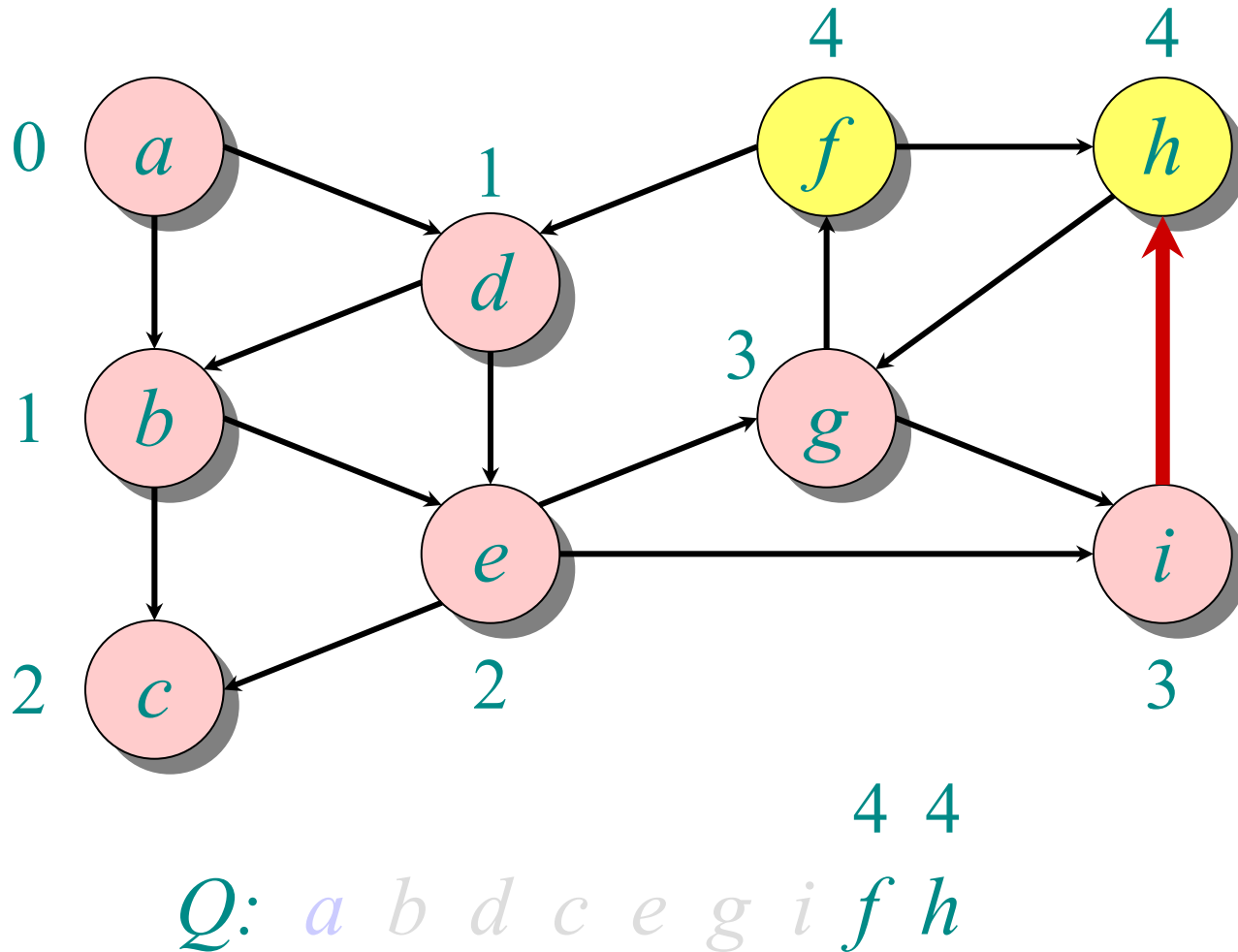

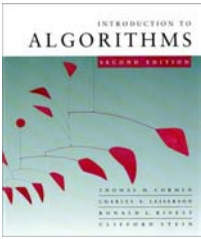

Example of breadth-first search

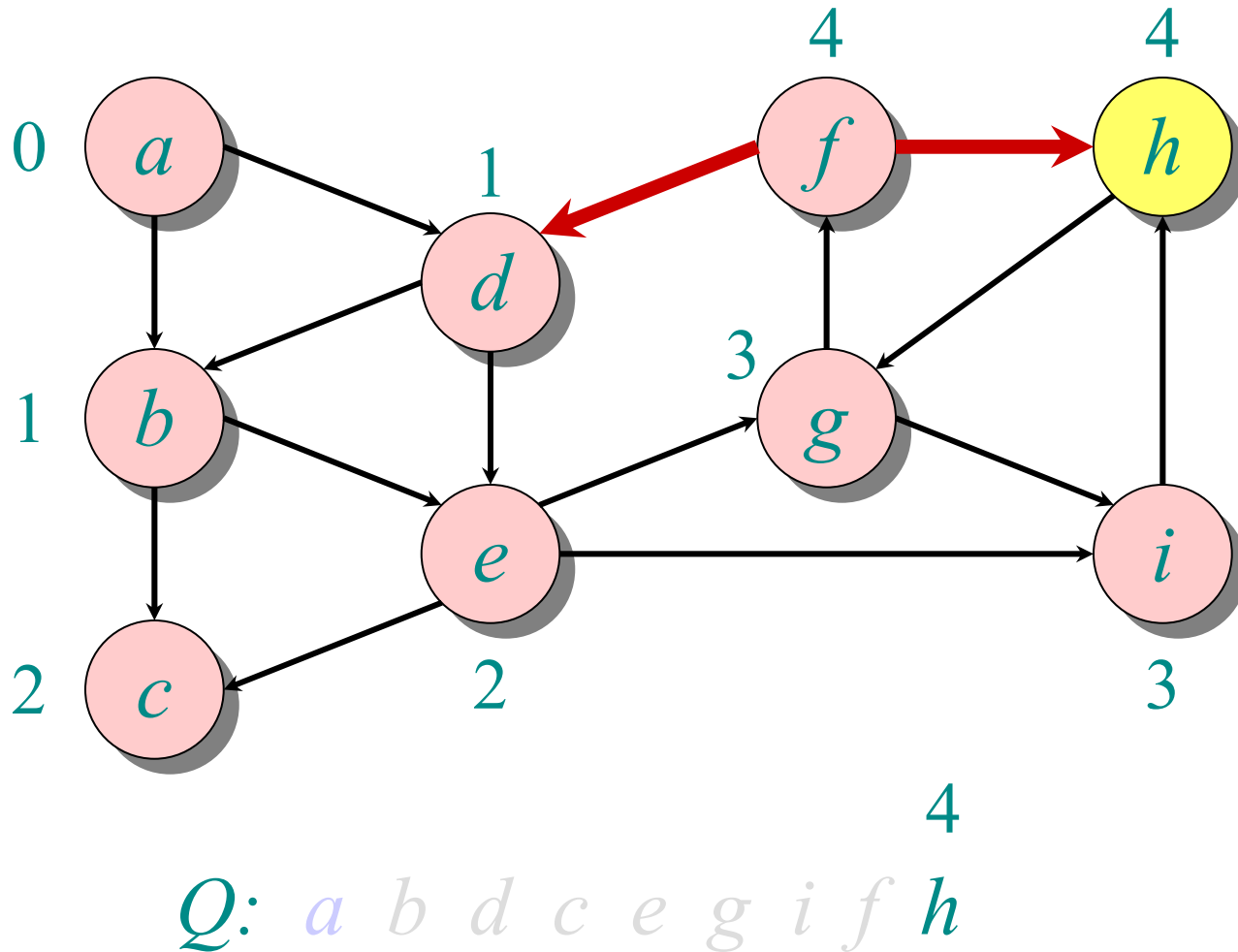

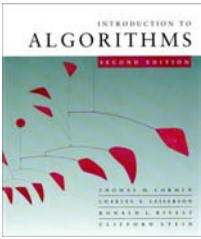

Example of breadth-first search

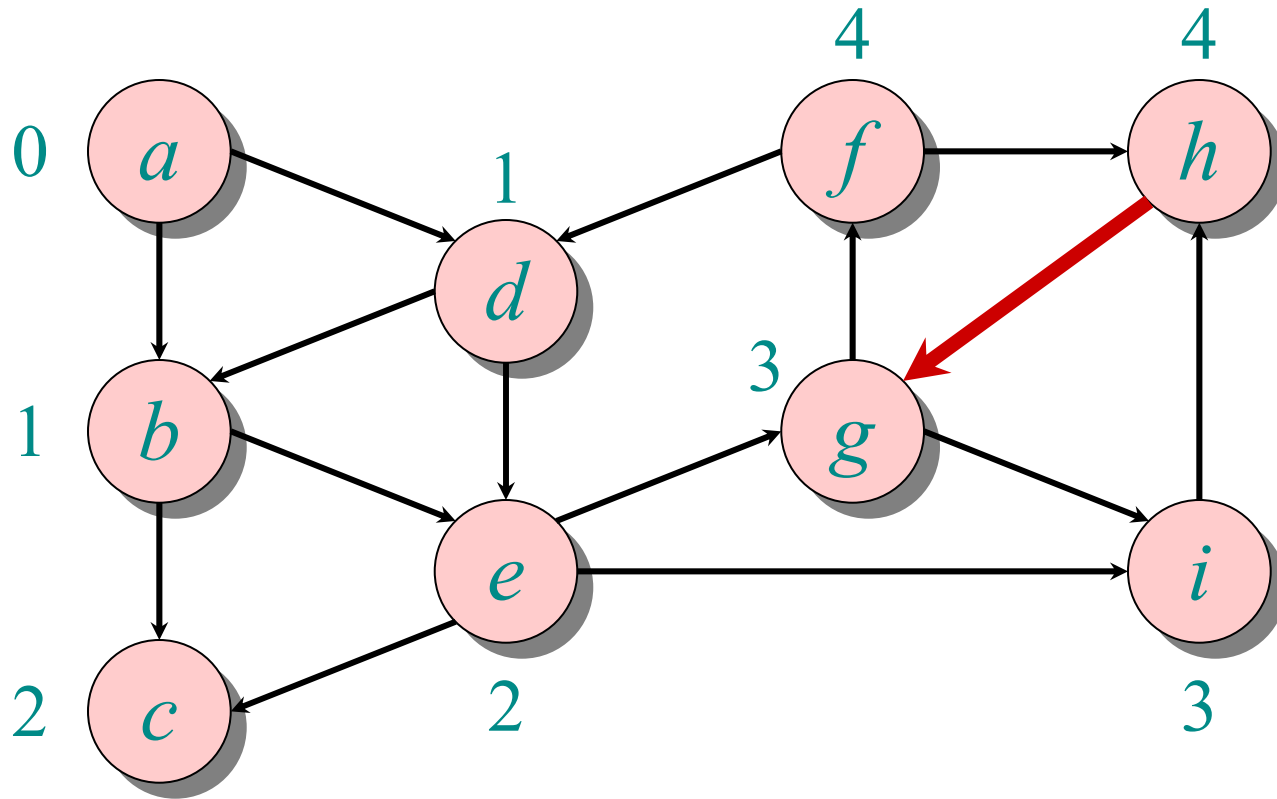

Q: *a b d c e g i f h*

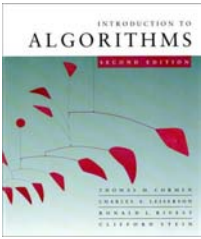

Example of breadth-first search

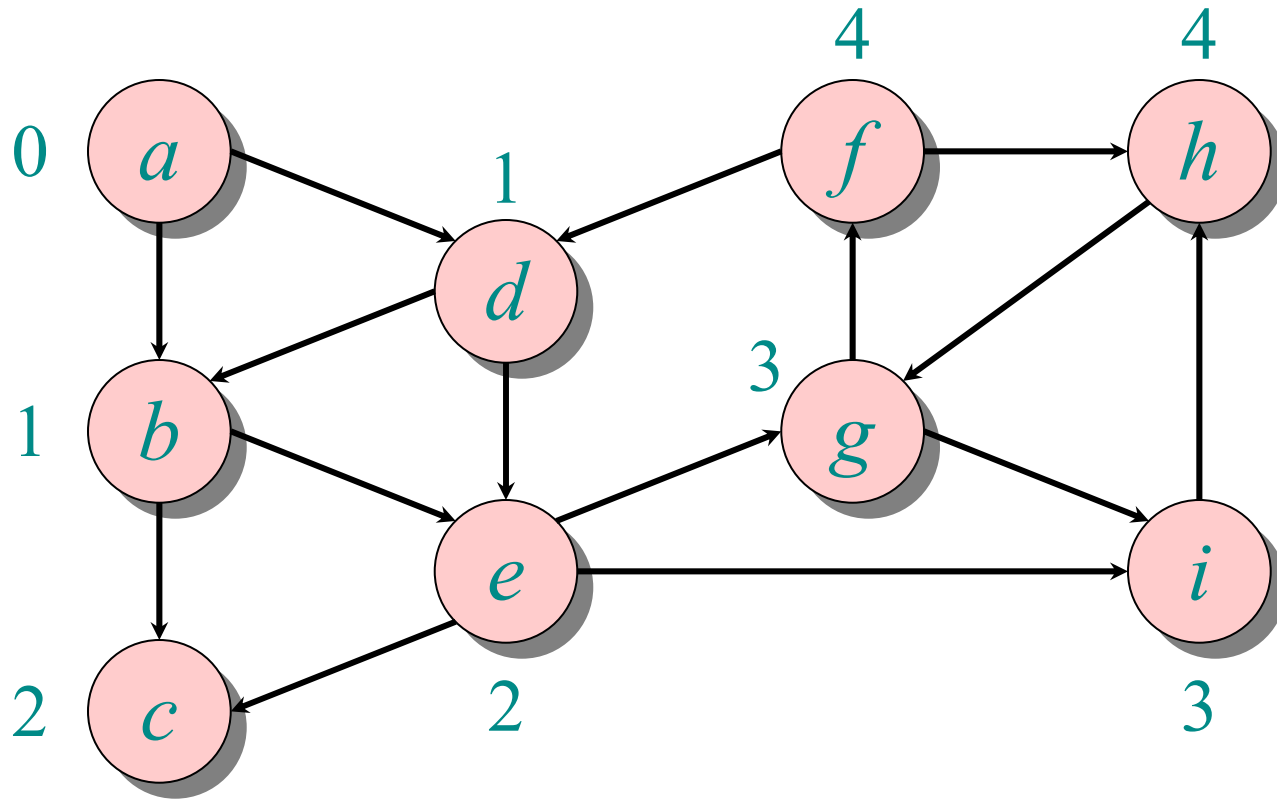

Q: a b d c e g i f h



Correctness of BFS

```
while  $Q \neq \emptyset$ 
do  $u \leftarrow \text{DEQUEUE}(Q)$ 
  for each  $v \in \text{Adj}[u]$ 
  do if  $d[v] = \infty$ 
    then  $d[v] \leftarrow d[u] + 1$ 
      ENQUEUE( $Q, v$ )
```

Key idea:

The FIFO Q in breadth-first search mimics the priority queue Q in Dijkstra.

- **Invariant:** v comes after u in Q implies that $d[v] = d[u]$ or $d[v] = d[u] + 1$.



How to find the actual shortest paths?

Store a predecessor tree:

$d[s] \leftarrow 0$

for each $v \in V - \{s\}$

do $d[v] \leftarrow \infty$

$S \leftarrow \emptyset$

$Q \leftarrow V$ $\triangleright Q$ is a priority queue maintaining $V - S$

while $Q \neq \emptyset$

do $u \leftarrow \text{EXTRACT-MIN}(Q)$

$S \leftarrow S \cup \{u\}$

for each $v \in \text{Adj}[u]$

do if $d[v] > d[u] + w(u, v)$

then $d[v] \leftarrow d[u] + w(u, v)$

$\pi[v] \leftarrow u$

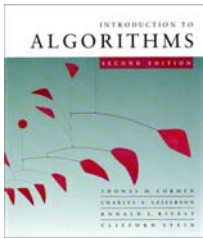

Example of Dijkstra's algorithm

Graph with nonnegative edge weights:

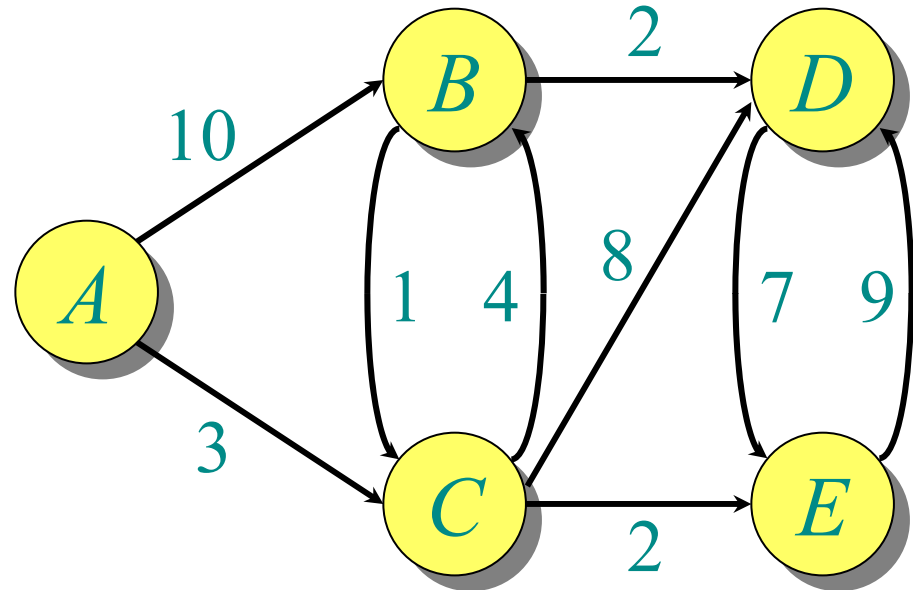

```
while  $Q \neq \emptyset$  do
   $u \leftarrow \text{EXTRACT-MIN}(Q)$ 
   $S \leftarrow S \cup \{u\}$ 
  for each  $v \in \text{Adj}[u]$  do
    if  $d[v] > d[u] + w(u, v)$  then
       $d[v] \leftarrow d[u] + w(u, v)$ 
       $\pi[v] \leftarrow u$ 
```



Example of Dijkstra's algorithm

Initialize:

$S: \{\}$

$Q:$

A	B	C	D	E
0	∞	∞	∞	∞

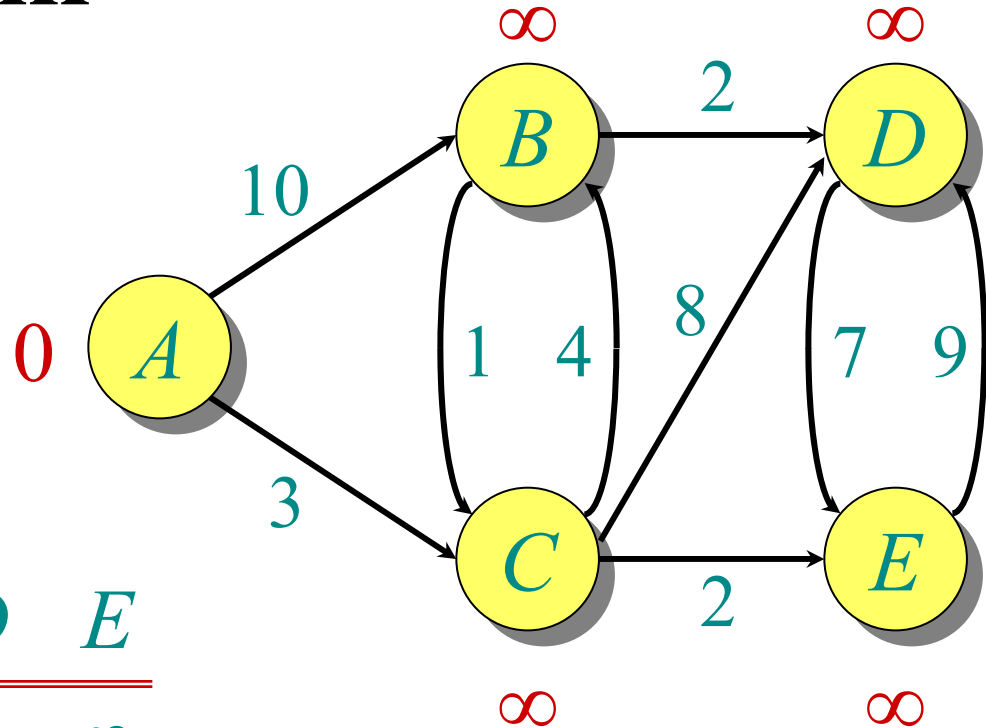

```
while  $Q \neq \emptyset$  do
   $u \leftarrow \text{EXTRACT-MIN}(Q)$ 
   $S \leftarrow S \cup \{u\}$ 
  for each  $v \in \text{Adj}[u]$  do
    if  $d[v] > d[u] + w(u, v)$  then
       $d[v] \leftarrow d[u] + w(u, v)$ 
       $\pi[v] \leftarrow u$ 
```

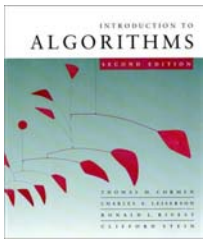

Example of Dijkstra's algorithm

“A” ← **EXTRACT-MIN**(Q):

S: { A }

π : A B C D E

Q: A B C D E

0 ∞ ∞ ∞ ∞

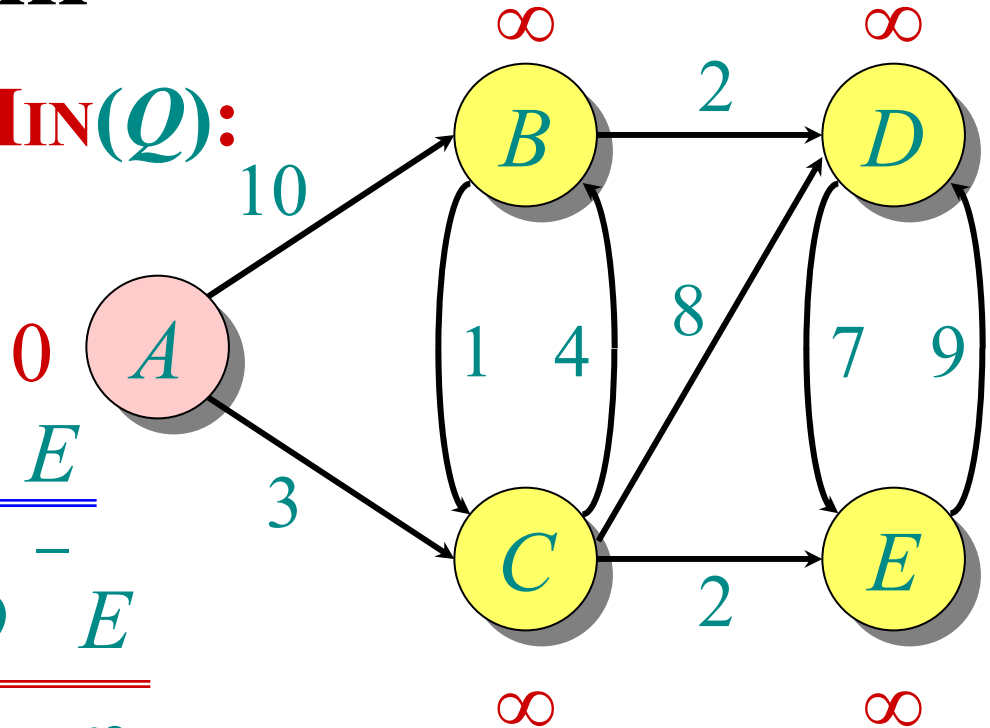

```

while  $Q \neq \emptyset$  do
   $u \leftarrow$  EXTRACT-MIN( $Q$ )
   $S \leftarrow S \cup \{u\}$ 
  for each  $v \in \text{Adj}[u]$  do
    if  $d[v] > d[u] + w(u, v)$  then
       $d[v] \leftarrow d[u] + w(u, v)$ 
       $\pi[v] \leftarrow u$ 
  
```



Example of Dijkstra's algorithm

Relax all edges leaving A :

$S: \{A\}$

$\pi: \underline{A \quad B \quad C \quad D \quad E}$

$Q:$	A	B	C	D	E
	0	∞	∞	∞	∞
		10	3	-	-

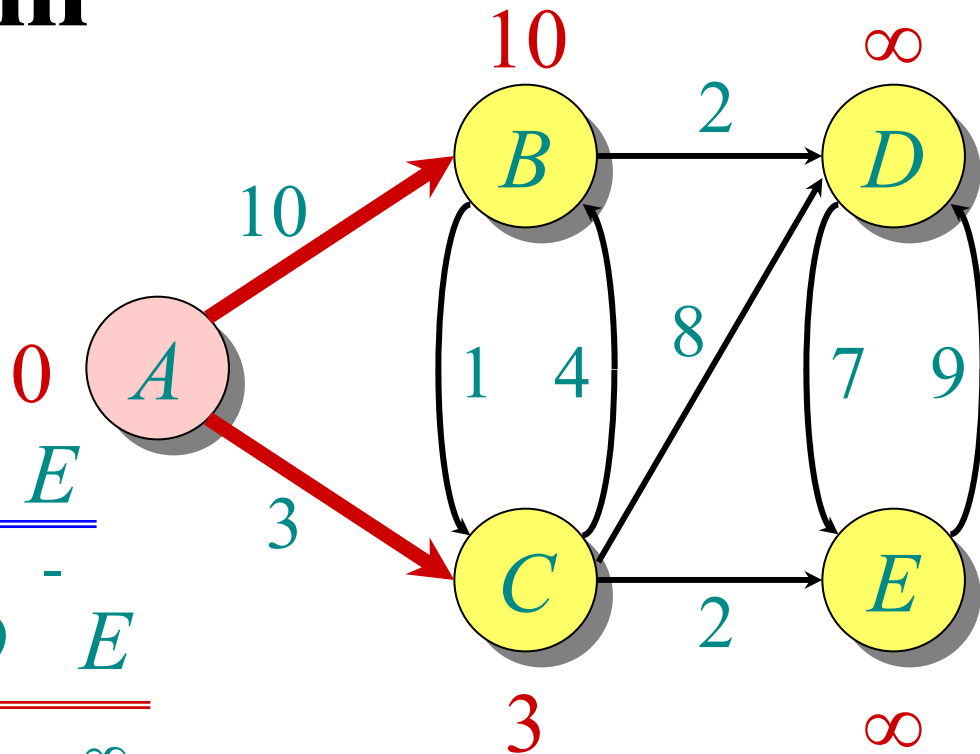

```

while  $Q \neq \emptyset$  do
   $u \leftarrow \text{EXTRACT-MIN}(Q)$ 
   $S \leftarrow S \cup \{u\}$ 
  for each  $v \in \text{Adj}[u]$  do
    if  $d[v] > d[u] + w(u, v)$  then
       $d[v] \leftarrow d[u] + w(u, v)$ 
       $\pi[v] \leftarrow u$ 
  
```



Example of Dijkstra's algorithm

Relax all edges leaving A :

$S: \{A\}$

$\pi:$

A	B	C	D	E
-	A	A	-	-

$Q:$

A	B	C	D	E
0	∞	∞	∞	∞
	10	3	-	-

0	∞	∞	∞	∞
	10	3	-	-

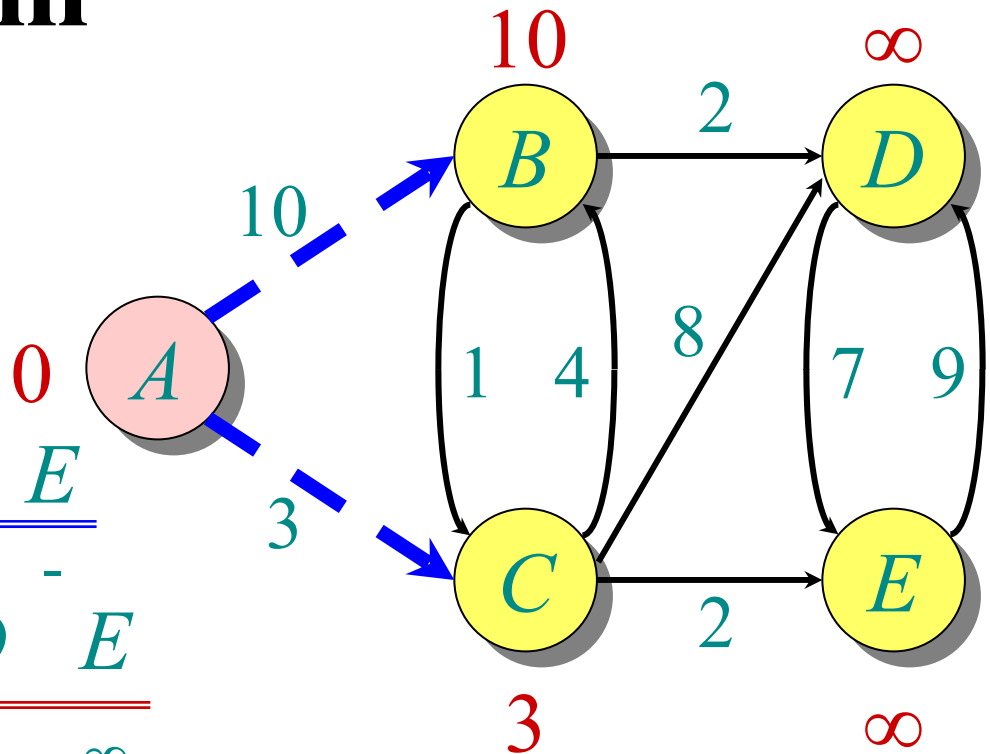

```

while  $Q \neq \emptyset$  do
   $u \leftarrow \text{EXTRACT-MIN}(Q)$ 
   $S \leftarrow S \cup \{u\}$ 
  for each  $v \in \text{Adj}[u]$  do
    if  $d[v] > d[u] + w(u, v)$  then
       $d[v] \leftarrow d[u] + w(u, v)$ 
       $\pi[v] \leftarrow u$ 
  
```

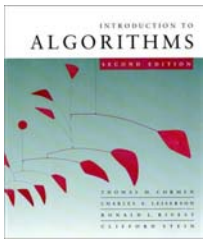

Example of Dijkstra's algorithm

“C” ← EXTRACT-MIN(Q):

S: { A, C }

π : A B C D E
 - A A - -

Q:	A	B	C	D	E
	0	∞	∞	∞	∞
		10	3	-	-

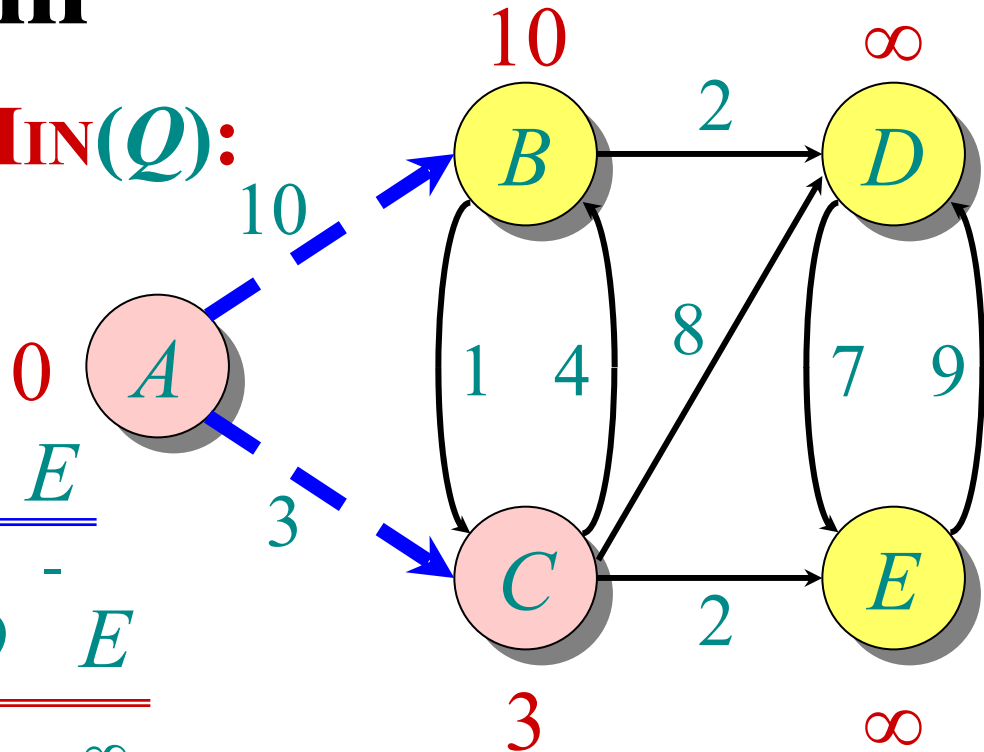

```

while Q ≠ ∅ do
  u ← EXTRACT-MIN(Q)
  S ← S ∪ {u}
  for each v ∈ Adj[u] do
    if d[v] > d[u] + w(u, v) then
      d[v] ← d[u] + w(u, v)
      π[v] ← u
  
```



Example of Dijkstra's algorithm

Relax all edges leaving C :

$S: \{A, C\}$

$\pi:$

A	B	C	D	E
-	A	A	-	-

$Q:$

A	B	C	D	E
0	∞	∞	∞	∞
	10	3	-	-
	7		11	5

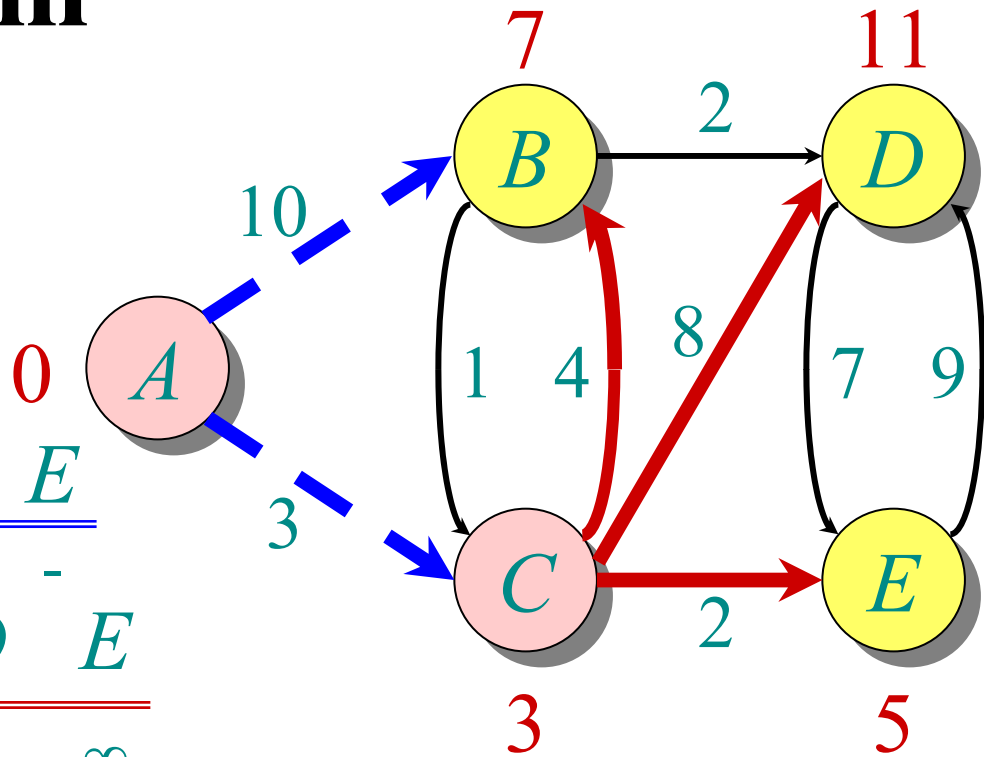

```

while  $Q \neq \emptyset$  do
   $u \leftarrow \text{EXTRACT-MIN}(Q)$ 
   $S \leftarrow S \cup \{u\}$ 
  for each  $v \in \text{Adj}[u]$  do
    if  $d[v] > d[u] + w(u, v)$  then
       $d[v] \leftarrow d[u] + w(u, v)$ 
       $\pi[v] \leftarrow u$ 
  
```



Example of Dijkstra's algorithm

Relax all edges leaving C :

$S: \{A, C\}$

$\pi:$ A B C D E

- A A - -

$Q:$ A B C D E

0	∞	∞	∞	∞
	10	3	-	-
	7		11	5

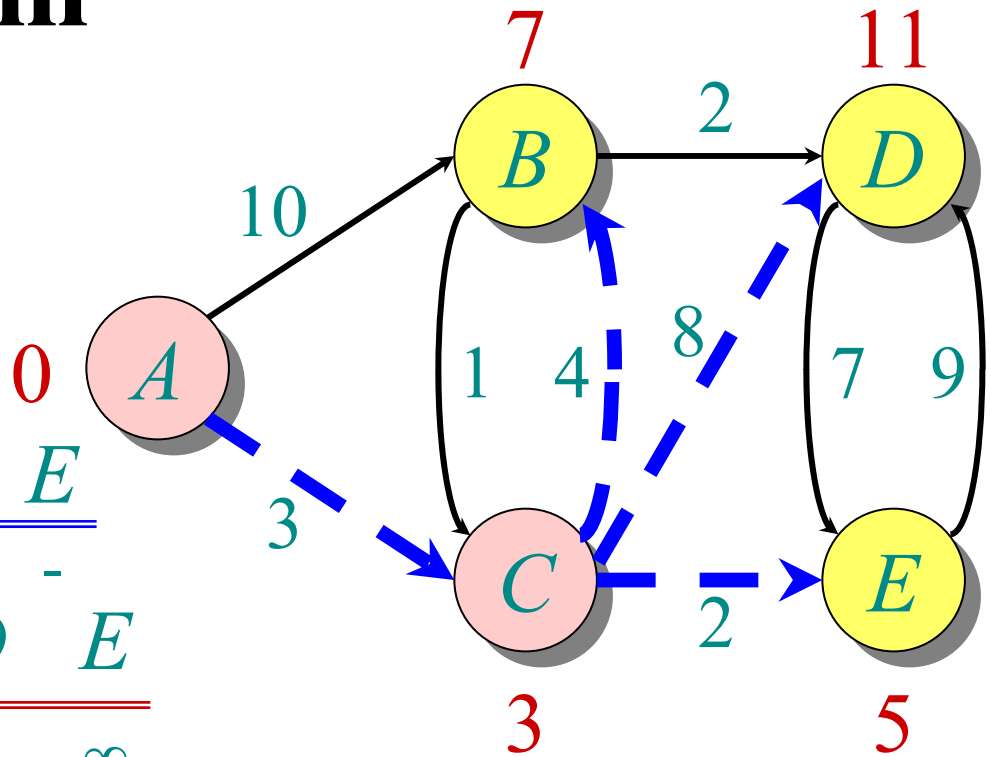

```

while  $Q \neq \emptyset$  do
   $u \leftarrow \text{EXTRACT-MIN}(Q)$ 
   $S \leftarrow S \cup \{u\}$ 
  for each  $v \in \text{Adj}[u]$  do
    if  $d[v] > d[u] + w(u, v)$  then
       $d[v] \leftarrow d[u] + w(u, v)$ 
       $\pi[v] \leftarrow u$ 
  
```



Example of Dijkstra's algorithm

“E” ← **EXTRACT-MIN**(Q):

$S: \{A, C, E\}$ 0

$\pi:$ A B C D E

 - C A C C

$Q:$ A B C D E

0	∞	∞	∞	∞
	10	3	-	-
	7		11	5

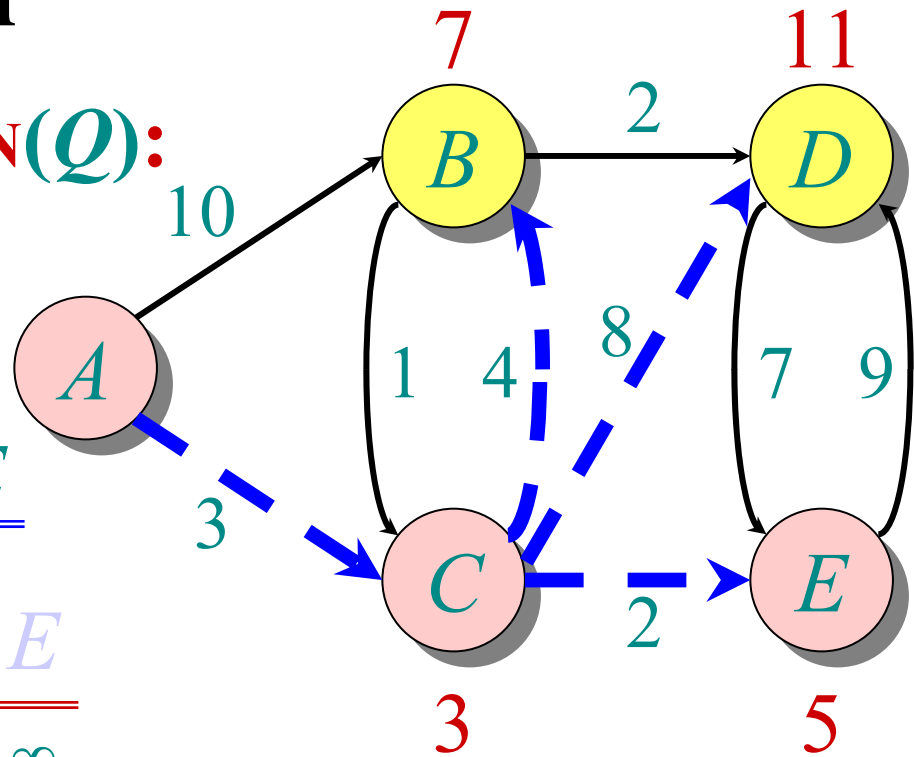

```

while  $Q \neq \emptyset$  do
   $u \leftarrow \text{EXTRACT-MIN}(Q)$ 
   $S \leftarrow S \cup \{u\}$ 
  for each  $v \in \text{Adj}[u]$  do
    if  $d[v] > d[u] + w(u, v)$  then
       $d[v] \leftarrow d[u] + w(u, v)$ 
       $\pi[v] \leftarrow u$ 
  
```



Example of Dijkstra's algorithm

Relax all edges leaving E :

$S: \{A, C, E\}$

$\pi:$

A	B	C	D	E
-	C	A	C	C

$Q:$

A	B	C	D	E
0	∞	∞	∞	∞
10	3	∞	∞	∞
7		11	5	
7		11		

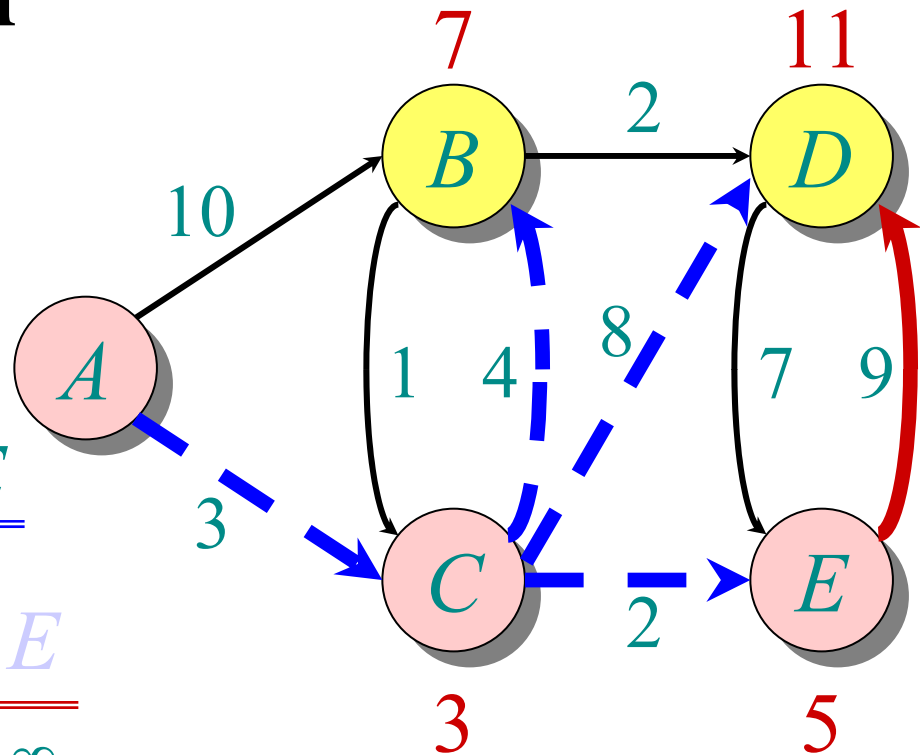

```

while  $Q \neq \emptyset$  do
   $u \leftarrow \text{EXTRACT-MIN}(Q)$ 
   $S \leftarrow S \cup \{u\}$ 
  for each  $v \in \text{Adj}[u]$  do
    if  $d[v] > d[u] + w(u, v)$  then
       $d[v] \leftarrow d[u] + w(u, v)$ 
       $\pi[v] \leftarrow u$ 
  
```



Example of Dijkstra's algorithm

“B” ← EXTRACT-MIN(Q):

S: { A, C, E, B } 0

π : A B C D E
 - C A C C

Q:	A	B	C	D	E
	0	∞	∞	∞	∞
	10	3	∞	∞	∞
	7		11	5	
	7		11		

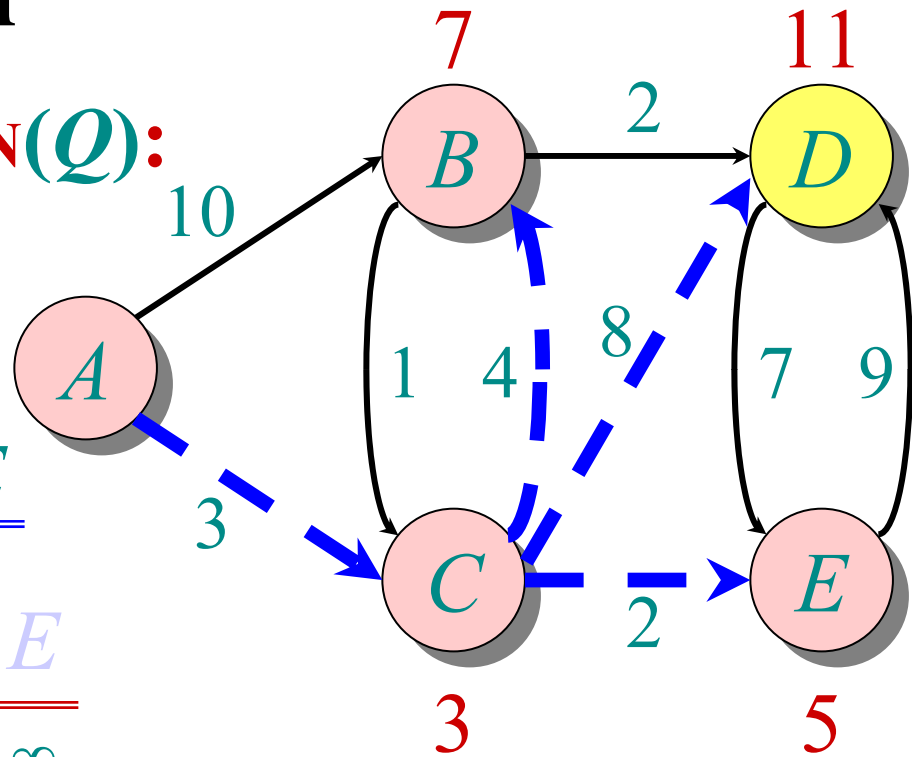

```

while Q ≠ ∅ do
  u ← EXTRACT-MIN(Q)
  S ← S ∪ {u}
  for each v ∈ Adj[u] do
    if d[v] > d[u] + w(u, v) then
      d[v] ← d[u] + w(u, v)
      π[v] ← u
  
```

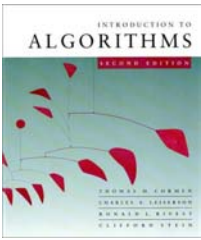

Example of Dijkstra's algorithm

Relax all edges leaving B :

$S: \{A, C, E, B\}$ 0

$\pi:$

 - C A B C

$Q:$	A	B	C	D	E
	0	∞	∞	∞	∞
		10	3	∞	∞
		7		11	5
		7		11	
				9	

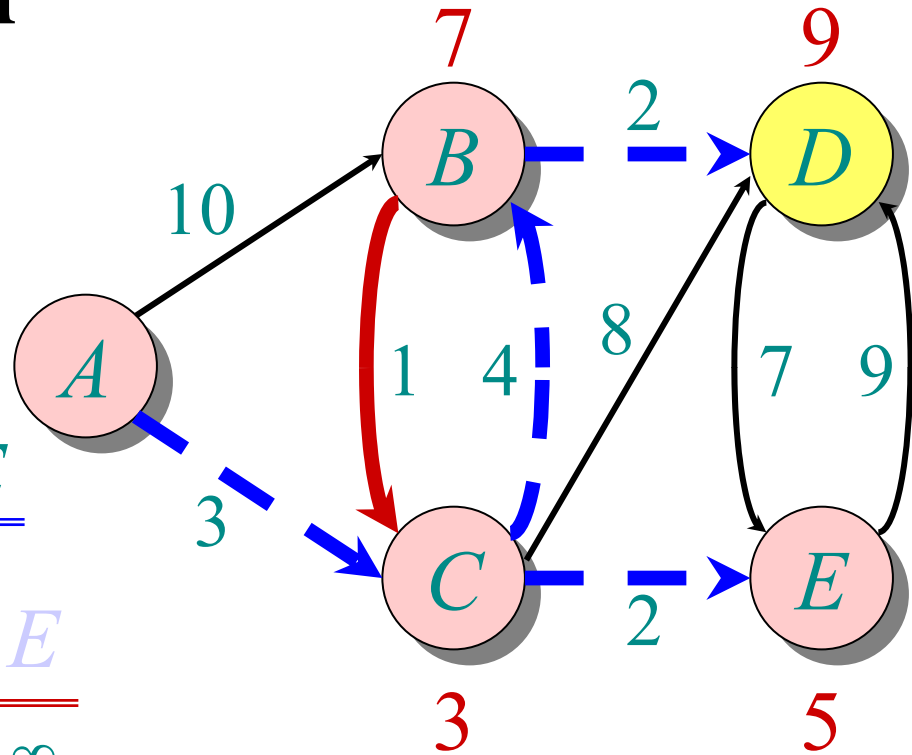

```

while  $Q \neq \emptyset$  do
   $u \leftarrow \text{EXTRACT-MIN}(Q)$ 
   $S \leftarrow S \cup \{u\}$ 
  for each  $v \in \text{Adj}[u]$  do
    if  $d[v] > d[u] + w(u, v)$  then
       $d[v] \leftarrow d[u] + w(u, v)$ 
       $\pi[v] \leftarrow u$ 
  
```

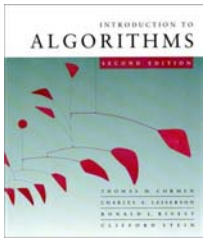

Example of Dijkstra's algorithm

“D” ← **EXTRACT-MIN**(Q):

S: { A, C, E, B, D } 0

π : A B C D E
 - C A C C

Q:	A	B	C	D	E
	0	∞	∞	∞	∞
		10	3	∞	∞
		7		11	5
		7		11	
				9	

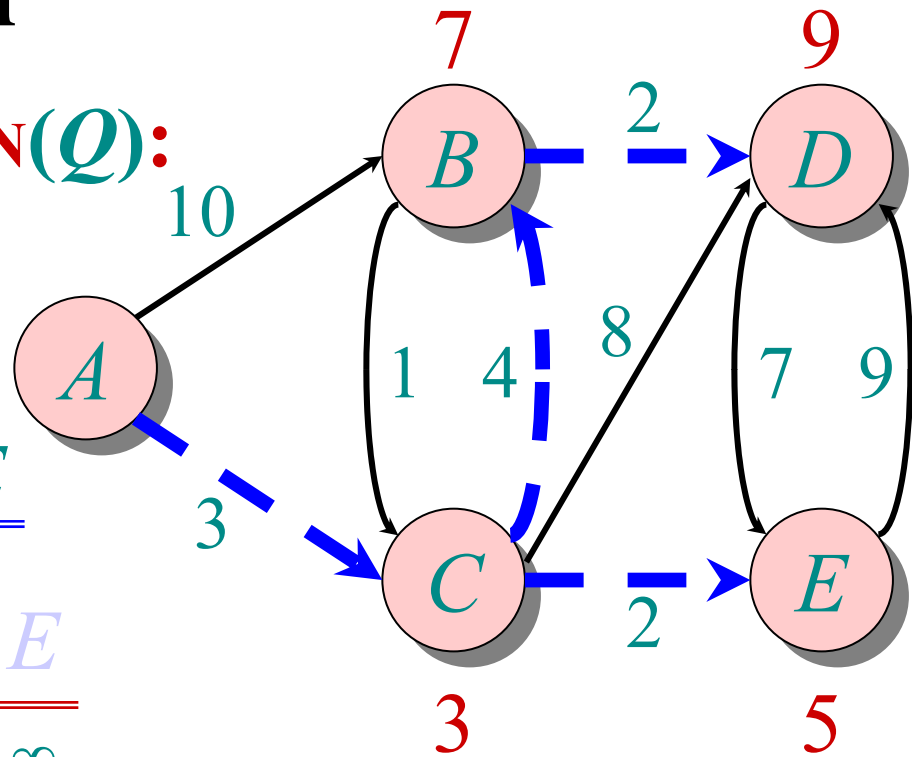

```

while Q ≠ ∅ do
  u ← EXTRACT-MIN(Q)
  S ← S ∪ {u}
  for each v ∈ Adj[u] do
    if d[v] > d[u] + w(u, v) then
      d[v] ← d[u] + w(u, v)
      π[v] ← u
  
```